

Evolution Elite™ (Electric)

Reduced Oil Capacity Open Fryer



01180134

EEE-141
EEE-142
EEE-143
EEE-144



Table of Contents



Safety.....	iii
Chapter 1 Troubleshooting	1
1.1 Introduction	1
1.2 Troubleshooting	1
1.3 Error Codes	3
Chapter 2 Info & Filter Button Stats	7
2.1 Info & Filter Button Stats	7
2.1.1 Filter Button Stats	7
2.1.2 Info Button Stats	7
Chapter 3 Information Mode	9
Chapter 4 Product Program Mode	17
4.1 Modifying Product Settings	17
Chapter 5 Level 2 Programming.....	21
5.1 Special Program Mode	21
5.2 Do Not Disturb	29
5.3 Clock Set.....	30
5.4 Data Logging, Heat Control, Tech, Stat, & Filter Control Modes.....	30
5.5 Tech Mode.....	31
5.6 Stats Mode	36
Chapter 6 Maintenance	39
6.1 Introduction	39
6.2 Maintenance Hints	39
6.3 Preventative Maintenance	39
6.4 Control Panel & Menu Card Replacement	40
6.5 High Temperature Limit Control	42
6.5.1 Checkout.....	42
6.5.2 Replacement	43
6.6 Breakers	49
6.6.1 Checking Procedure for Breaker	51
6.7 Main Power Switch.....	51
6.7.1 Checkout.....	52
6.8 Temperature Probe Replacement.....	53
6.8.1 Checkout.....	53
6.8.2 Replacement	54
6.9 Oil Channel Clean-Out	57
6.10 Element Safety Switch.....	57
6.10.1 Checkout.....	58
6.10.2 Replacement	58
6.11 Contactors	60
6.11.1 Checkout	61
6.11.2 Replacement	63
6.12 Solenoid Valves	65
6.12.1 Replacement	66

6.13	Filter Pump & Motor for Units Manufactured Prior to September 2018	69
6.13.1	Removing Debris from Pump	69
6.13.2	Resetting Thermal Overload Switch.....	71
6.13.3	Motor Removal	71
6.13.4	Replacement Of Pump Motor.....	73
6.14	HubMounted Filter Pump and Motor Assembly	74
6.14.1	Removing Debris from Pump	74
6.14.2	Replacing the Hubmounted Filter Pump	75
6.14.3	Replacing the Motor Assembly.....	78
6.15	JIB Pump.....	79
6.15.1	Replacement	79
6.16	Express Filter PC Board	80
6.16.1	Replacement	80
6.17	Transformers	82
6.17.1	Checkout.....	82
6.17.2	Replacement	83
6.18	Installing Arby's SiteSage Radio.....	84
6.18.1	Installing SiteSage Radio Hardware	84
6.18.2	Enabling the Control MODBUS	87
6.19	Filter Motor Relay.....	87
6.20	Drain Pan Switch.....	89
6.20.1	Replacement	89
6.21	Filter Beacon®.....	91
6.21.1	Replacement	91
6.22	Oil Level Probes.....	92
6.22.1	Checkout.....	93
6.22.2	Replacement	94
6.23	Drain Rod Microswitch.....	96
6.23.1	Checkout.....	96
6.23.2	Replacement	97
Chapter 7	Wiring Diagrams.....	99
7.1	208/240 Volt	99
7.2	380-414 Volt	104

Safety

Henny Penny fryers have many safety features incorporated. However, the only way to ensure safe operation is to fully understand the proper installation, operation, and maintenance procedures. The instructions in this manual have been prepared to aid you in learning the proper procedures. Where information is of particular importance or is safety related, the words DANGER, WARNING, CAUTION, or NOTICE are used. Their usage is described as follows:

 DANGER	DANGER! indicates hazardous situation which, if not avoided, will result in death or serious injury.
DANGER!	
 WARNING	WARNING! indicates hazardous situation which, if not avoided, could result in death or serious injury.
WARNING!	
 CAUTION	CAUTION! indicates hazardous situation which, if not avoided, could result in moderate or minor injury.
CAUTION!	
<i>NOTICE</i>	<i>NOTICE</i> is used for information considered important regarding property damage.

	SHOCK HAZARD SYMBOLS
	HOT SURFACE SYMBOLS

These are the original version controlled Henny Penny instructions for Evolution Elite Reduced Oil Capacity Open Fryer Model EEE 141, 142, 143, and 144. This manual is available on the Henny Penny Public website (www.hennypenny.com). Read these instructions completely prior to installation and operation of this appliance to ensure compliance to all required installation, operation and safety standards. Read and obey all safety messages to avoid damage to the appliance and personal injury.



WARNING

- This fryer must be installed and used in a way that water does not contact the oil which can cause splashing and boiling over of oil and steam leading to personal injury; excludes normal product moisture.
- Burn risk! Do not move the fryer or filter drain pan while containing hot oil. Personal injury or serious burns can result from splashing hot oil.

This appliance is intended for commercial use in kitchens of restaurants, bakeries, hospitals, etc. but not for the continuous mass production of food such as in a factory setting. During use the units airborne A-weighted emission sound pressure is below 70 db(A). All repairs must be performed by the manufacturer, its service agent or similarly qualified persons in order to avoid a hazard.

Always use strain relief. Install the provided power cord with the ground wire dimensioned to fail last. If the supplied power cord or an existing one becomes damaged, do not use it; rather, replace it with a known good power cord. The power cord must be replaced by the manufacturer, its service agent or similarly qualified persons in order to avoid a hazard.

Proper daily, weekly, monthly, quarterly and yearly maintenance must be performed on this appliance to ensure safe and continuous operation. This appliance must never be cleaned with a water jet or steam cleaning tool. Cleaning brushes are shipped with the appliance and proper cleaning instructions are included in this manual.

Proper maintenance also increases the usable life of the appliance and oil, which reduces lifetime operating costs. Additionally, old oil increases the possibility of surge boiling and fire due to the reduced flash point of the oil. The oil temperature must never exceed 450° F (230° C).

This appliance is not intended for use by persons (including children) with reduced physical, sensory or mental capabilities, or lack of experience and knowledge, unless they have been given supervision or instruction concerning use of the appliance by a person responsible for their safety. Children should be supervised to ensure that they do not play with the appliance.

This appliance is not intended to be operated by means of an external timer or a separate remote control system.

Chapter 1 Troubleshooting

1.1 Introduction

This section provides troubleshooting information in the form of an easy to read table. If a problem occurs during the first operation of a new fryer, recheck the installation per Chapter 2 Installation of the Operator's manual. Before troubleshooting, always recheck the operation procedures per Chapter 3 of the Operator's manual.

1.2 Troubleshooting

To isolate a malfunction, proceed as follows:

- 1) Clearly define the problem (or symptom) and when it occurs.
- 2) Locate the problem in the Troubleshooting table.
- 3) Review all possible causes. Then, one-at-a-time work through the list of corrections until the problem is solved.
- 4) Refer to the maintenance procedures in the Maintenance Section to safely and properly make the checkout and repair needed.



WARNING If maintenance procedures are not followed correctly, injuries and/or property damage could result.

Table 1-1 Troubleshooting

Problem	Cause	Correction
Power switch ON but fryer completely inoperative.	Open circuit.	<ul style="list-style-type: none"> • Plug fryer in. • Check breaker or fuse at supply box. • Non-US/Some Int'l Locations Only Breakers in fryer tripped: open left door and reset breaker on fryer.
Oil will not heat but lights are on.	All power cords not plugged in.	Unit has two power cords; make sure both are plugged in.
Control error "E-10".	Open high limit circuit.	Let unit cool down (15-20 minutes), reset the high limit using the high limit tool on the inside of the LH door and gently pushing it into the hole in the heating element hinge; if high limit does not reset, high limit must be replaced.
Vat is under-filled.	Jib is low or empty.	Fill the JIB.
	JIB oil line is clogged or collapsed.	Check JIB line.

Problem	Cause	Correction
	Filter pan needs cleaned.	Clean filter pan and change paper or pad.
Oil foaming or boiling over top of vat.	Water in oil.	Drain and clean oil.
	Improper or bad oil.	Use recommended oil.
	Improper filtering.	Refer to filtering procedures.
	Improper rinsing after cleaning the vat.	Clean and rinse vat and then dry thoroughly.
Oil will not drain from vat.	Drain valve clogged with crumbs.	Open valve, force cleaning brush through drain.
	Drain trough clogged.	Remove right side panel and remove plug from end of trough, clean trough.
Filter motor runs but pumps oil slowly.	Filter line connections loose.	Tighten all filter line connections.
	Filter paper or pad clogged.	Change filter paper or pad.
Bubbles in oil during entire filtering process.	Filter pan not completely engaged.	Make sure filter pan return line is pushed completely into the receiver on the fryer.
	Filter pan clogged.	Clean pan and change paper or pad.
	Damaged O-ring on filter line receiver on fryer.	Replace O-ring.
Control error code "E-31"	Elements are up.	Lower elements back into vat.
Filter motor will not run.	Power cord for vat #1 is not plugged in.	Plug power cord into receptacle.
	Open circuit.	Breakers in fryer tripped; open left door and reset breaker on fryer.
	Thermal reset button on the rear of the pump motor is tripped.	Allow motor to cool, then, using the handle of a screwdriver, press hard against the button until it clicks.
Displayed Prompt Section		

Problem	Cause	Correction
“IS POT FILLED” filter error prompt.	All oil did not completely return after a filter cycle.	<ul style="list-style-type: none"> • Have manager follow prompts. • Is JIB full? If not, fill JIB.
“CHECK PAN” prompt.	Filter pad clogged.	Replace filter pad/clean pan.
“FILTER PAN MISSING” prompt.	Filter pan not completely engaged.	Adjust filter pan.
	Filter pan missing.	Find pan and replace.
	Filter pan inter-lock not engaged.	Adjust filter pan to engage interlock.
“CHANGE FILTER PAD” prompt appears	Filter pad has not been changed within a 24 hr time period; Main power switch was turned off during filter pad change	Replace old filter pad with NEW filter pad while main power switch is in ON position. 24/7 stores should replace filter twice a day.
	Drain pan micro-switch stuck	Check microswitch.

1.3 Error Codes

In the event of a control system failure, the digital display shows an error message. The message codes are shown in the display column below. A constant tone is heard when an error code is displayed. To silence this tone, press any button.

Table 1-2 Error Codes

Display	Cause	Panel Board Correction
“E-4”	Control board overheating.	Turn switch to OFF position, then turn switch back to ON; if display shows “E-4”, the control board is getting too hot; check the louvers on each side of the unit for obstruction.
“E-5”	Oil overheating.	Turn switch to OFF position, then back to ON; if display shows “E-5”, the heating circuits and temperature probe should be checked.
“E-6A”	Temperature probe open.	Turn switch to OFF position, then back to ON; if the display shows “E-6”, the temperature probe should be checked.
“E-6B”	Temperature probe shorted.	

Display	Cause	Panel Board Correction
"E-10"	High limit.	Let the unit cool down (15-20 minutes), insert the high limit tool, on the inside of the LH door, gently into the hole in the heating element hinge. If the high limit does not reset, high limit must be replaced.
"E-15"	Drain switch.	Make sure drain knob is completely pushed-in; if E-15 persists, have drain switch checked.
"E-18A"	Left level sensor open.	Turn switch to OFF position, then back to ON; if display still indicates a failed sensor, have the connections checked on the control board. Have sensor check and replaced if necessary.
"E-18B"	Right level sensor open.	
"E-18C"	Both level sensors open.	
"E-21"	Slow heat recovery.	Have a certified service technician check the fryer for correct voltage to the unit; have heat circuit checked; have unit checked for loose or burnt wires.
"E-22" "NO HEAT" "CHECK PWR CORD AND BREAKER"	Elements not heating.	Have power cord and heat circuit checked.
"E-31"	Elements are up.	Lower elements completely back into the vat.
"E-41" "E-46"	Programming failure.	Turn power switch to OFF, then back to ON; if display shows an error code, have the controls re-initialized; if error code persists, have the control board replaced.
"E-47"	Analog converter chip or 12-volt supply failure.	Turn power switch OFF, then back to ON; if "E-47" persists, have the I/O board, or the PC board replaced; if speaker tones are quiet, probably I/O board failure; have the I/O board replaced.
"E-48"	Input system error.	Have PC board replaced.
"E-54C"	Temperature input error.	Turn power switch to OFF, then back to ON; have control PC board replaced if "E-54C" persists.
"E-60"	AIF PC board not communicating with PC board.	Turn power switch to OFF, wait 15 seconds, then turn switch back to ON. If "E-60" persists, have connector between the PC boards checked; replace AIF PC board or control PC board if necessary.

Display	Cause	Panel Board Correction
"E-83R"	Bulk Dispose switch on when pressure too high.	Check Bulk Dispose quick-disconnect behind fryer.
"E-93A" "24 VDC SUPPLY TRIPPED"	Autolift motor malfunction or failure.	If AutoLift feature is not operating, have each of the Auto-lift motors checked.

Chapter 2 Info & Filter Button Stats

2.1 Info & Filter Button Stats

NOTE: If no buttons are pressed within 5 seconds in any of stats modes, the controls revert back to normal operation.

2.1.1 Filter Button Stats

Table 2-1 Filter Button Stats

Menu Step	Description
Cook Cycles Remaining Before Filtering	Press either filter button 1 time. The left display shows "COOKS REMAINING" and the right display shows the number of cook cycles before the next auto filter. For example, "REMAINING" "3 6", means after 3 more cook cycles on the left vat, the controls asks the operator if they are ready to filter or not. But, 6 more cook cycles remain on the right vat.
Time & Date	Press either filter button 2 times, "FILTERED" shows in the displays, along with time-of-day and date of the last filter.
Hours The Existing Filter Has Been Used	Press either filter button 3 times and "FLTR PAD" "XX HOURS" shows in displays to indicate the number of hours the existing filter has been used.

2.1.2 Info Button Stats

Table 2-2 Info Button Stats

Menu Step	Description
Actual Oil Temperature	Press the info button 1 time and the actual oil temperature shows in the display for each vat.
Set-Point Temperature	Press the info button 2 times and "SP" shows in the display, along with the set-point (preset) temperature of each vat.
Recovery Information For Each Vat	Press the info button 3 times and "REC" shows in the left display and the recovery time that oil temperature went from 250°F (121°C) to 300°F (149°C) shows in the right display. For example, "REC 5:30" means it took 5 minutes and 30 seconds for the oil temperature to recover to 300°F (149°C) from 250°F (121°C).



Info & Filter Button Stats

Chapter 3 Information Mode

This mode gathers and stores historic information on the fryer and operator's performance which can be used for operational and technical help and allows you to view the following:

1. E-Log
2. Last Load
3. Daily Stats
4. Oil Stats
5. Review Usage
6. Inputs
7. Outputs
8. Oil Temp
9. CPU Temp
10. Communication Info
11. Analog Info
12. Activity Log
13. Oil Levels
14. Pump Valve Info
15. AIF Info
16. USB Support

NOTE: Not all Information Mode functions are discussed in this section. To ensure proper operation of fryer, please consult Henny Penny Corp. before changing any of these settings. For more information on these functions, contact Technical Support at 1-800-417- 8405, or 1-937-456-8405.

To access Info Mode:

- 1) Press and hold the program and info button at the same time until “*INFO MODE*” flashes on the screen.

NOTE:

- Press the info button and program button to exit Information Mode at any time.
- Use the left or right arrow button to navigate through the info modes.

Table 3-1 Information Mode Details

Menu Step	Description
1. E-Log	<p>The E-Log section provides an error code log.</p> <ol style="list-style-type: none"> 1. Press the info button and program button at the same time and “*INFO MODE*” shows in the display, followed by “1. E-LOG”. 2. Press the down arrow button and “A. (date & time) *NOW*” show in displays. This is the present date and time. 3. Press the down arrow button and if an error was recorded, “B. (date, time, and error code information)” shows in display. This is the latest error code that the controls recorded. Sometimes the characters “L:” and “R:” appear in front of the error code on the display which refers to the left or right vat of a split vat. 4. Press the down arrow button and the next latest error code information can be seen. Up to 10 error codes (B to K) can be stored in the E-LOG section.
2. Last Load	<p>The Last Load section provides information on recent cook cycles.</p> <ol style="list-style-type: none"> 1. Press the right arrow button and “2. LAST LOAD” shows in displays. 2. Press a timer button for the product you want to view the cook data and the LED flashes. 3. Press the down arrow button to start viewing the cook data. For example, if the left timer 1 LED is flashing, “PRODUCT FRY L1” shows in displays. If the right timer 2 LED is flashing, “PRODUCT FRY R2” shows in displays. 4. Press the down arrow button to start viewing the cook data. See Table 3-2 Last Load Details, page 12.
3. Daily Stats	<p>The Daily Stats section provides operational information of the fryer for the last 7 days.</p> <ol style="list-style-type: none"> 1. Press the right arrow button and “3. DAILY STATS” shows in displays. 2. Press the down arrow button to start viewing the cook data. 3. Press the right timer 1 button to view data for other days of the week. See Table 3-3 Daily Stats Details, page 13.
4. Oil Stats	<p>The Oil Stats section provides information of current oil and average of last four batches of oil.</p>

Menu Step	Description
	<ol style="list-style-type: none"> 1. Press the right arrow button and "4. OIL STATS" shows in displays. 2. Press the down arrow button to start viewing the cook data. See Table 3-4 Oil Stats Details, page 14 3. Press and hold a product button (1 to 4) to view the data from one of the previous 4 batches of oil used. <ul style="list-style-type: none"> • Press product button 1 to view oldest oil data: Ex: OIL-4 14 DAYS • Press product button 2 to view 3rd oldest oil data: Ex: OIL-3 12 DAYS • Press product button 3 to view 2nd oldest oil data: Ex: OIL-2 15 DAYS • Press product button 4 to view previous batch of oil: Ex: OIL-1 13 DAYS <p>NOTE: To obtain the most accurate oil information, use the "3.DIS-POSE" step in the Filter Menu (press and hold the filter button) to drain the oil from the vat.</p>
5. Review Usage	<p>The Review Usage section provides accumulated info since the data was last reset.</p> <ol style="list-style-type: none"> 1. Press the right arrow button and "5. REVIEW USAGE" shows in displays. 2. Press the down arrow button to start viewing the cook data. See Table 3-5 Review Usage Details, page 14.
6. Inputs	<ol style="list-style-type: none"> 1. Press the right arrow button and "6. INPTS" and "HDE" show in displays. H = HIGH LIMIT - If "H" is present, the high limit is good. If "-" shows then the high limit is tripped out (overheated) or disconnected. D = DRAIN SWITCH - If "D" is present, the drain handle (when applicable) is closed. If "-" shows then the drain is open or the switch is faulty. E = Element switch - If "E" is present, the element switch is good. If "-" shows in the display, the element is in the upright position, or the switch is faulty.

Menu Step	Description
	<p>2. Press the down arrow button and an underscore (_) indicates the input is not presently detected. A checkmark (✓) indicates the signal is detecting a normal input. A blinking "X" indicates the signal is presently detected, but is detected as a half-wave (partially failed) input.</p> <p>NOTE: The H, D, E signals above are wired in series. The first signal missing out of this sequence I generally causes all signals to the right of it to be missing as well.</p>
7. Outputs	<p>1. Press the right arrow button and "7. OUPTS" and "S-H-" show in displays.</p> <p>S = SAFETY CONTACTOR - Press product button 6 to turn off and on the safety (primary) contactor.</p> <p>H = HEAT CONTACTOR - Press product button 7 to turn off and on the heat contactor. (product button 1 turns off and on the safety (primary) contactor for the left vat of a split vat fryer, and product button 2 turns off and on the heat contactor.)</p>
8. Oil Temperature	<p>1. Press the right arrow button and "8.OIL TMP" shows in the left display and the oil temperature shows in the right display.</p>
9. CPU Temperature	<p>1. Press the right arrow button and "9.CPU TMP" shows in the left display and the current PC board temperature shows in the right display.</p>

Table 3-2 Last Load Details

Function	Display Example
Product (Last Product Cooked)	PRODUCT FRY L1
Time Of Day The Last Cook Cycle Was Started	STARTED FEB-06 2:25P
Actual Elapsed Cook Time	ACTUAL TIME 1:06
Programmed Cook Time	PROG TIME 1:00
Max Temp During Cook Cycle	MAX TEMP 350°F
Min Temp During Cook Cycle	MIN TEMP 313°F
Avg Temp During Cook Cycle	AVG TEMP 322°F
Heat On (%) During Cook Cycle	HEAT ON 45%

Function	Display Example
Ready? (Was Fryer Ready Before Start?)	READY? YES
When Cook Cycle Was Stopped:	
Early	QUIT AT0: 10 REM
After Complete Cook Cycle	*DONE* +6 SEC
Difference (%) Between Actual And Programmed Cook Time	ACT/PROG 1%

Table 3-3 Daily Stats Details

Function	Display Example
Day for which this data was recorded	APR-30 TUE
Number of Hours: Minutes the fryer was on	(L/R) ON HRS TUE 3:45
Number of times filtered	(L/R) FILTERD TUE 4
Number of times filter skipped	(L/R) SKIPPED TUE 4
Number of times oil added	(L/R) ADD OIL TUE 4
Number of times oil discarded	(L/R) DISPOSE TUE 0
Oil temperature recovery time	(L/R) RECOVERY TUE 1:45
Total number of cook cycles that day	(L/R) TOT CK TUE 38
Number of cycles stopped before *DONE*	QUIT CK TUE 2
Cook Cycles for Product #1	COOK -1- TUE 17
Cook Cycles for Product #2	COOK -2- TUE 9
Cook Cycles for Product #3	COOK -3- TUE 5
Cook Cycles for Product #4	COOK -4- TUE 0
Cook Cycles for Product #5	COOK -5- TUE 0
Cook Cycles for Product #6	COOK -6- TUE 6
Cook Cycles for Product #7	COOK -7- TUE 0
Cook Cycles for Product #8	COOK -8- TUE 0

Function	Display Example
Cook Cycles for Product #9	COOK -9- TUE 1
Cook Cycles for Product #0	COOK -0- TUE 0

Table 3-4 Oil Stats Details

Function	Display Example
Start date of new oil	(L/R) NEW OIL MAR-23
Number of days oil in use	(L/R) OIL USE 4 DAYS
Number of filters on this oil	(L/R) FILTERD 4
Number of times filter skipped	(L/R) SKIPPED 0
Number of cook cycles on this oil	(L/R) TOT CK 38
Average number of days per oil change	(L/R) AVG DAYS PER OIL CHANGE 13.8 DAYS
Average number cook cycles per oil change	(L/R) AVG CKS PER OIL CHANGE 388 CKS

Table 3-5 Review Usage Details

Function	Display Example
Day the usage data was previously reset	SINCE APR-23 2011
Number of Hours the fryer was on	(L/R) ON HRS 4 4
Number of times filtered	(L/R) FILTERD 4 4
Number of times filter skipped	(L/R) SKIPPED 0 0
Number of times oil added	(L/R) ADD OIL 4 4
Number of times oil discarded	(L/R) DISPOSE 1 1
Total number of cook cycles	(L/R) TOT CK 38 38
Number of cycles stopped before *DONE*	QUIT CK 2 2
Cook Cycles for Product #1	COOK -1- 17 17
Cook Cycles for Product #2	COOK -2- 9 9
Cook Cycles for Product #3	COOK -3- 5 5
Cook Cycles for Product #4	COOK -4- 0 0

Chapter 4 Product Program Mode

This mode allows you to program the following:

- Change Product Name
- Assign Button
- Change Times & Temp
- Change Cook ID
- Alarms
- Quality Timers
- Include In Filter Count (Global)
- Filter After “X” Number Of Loads (Mixed)
- Load Compensation
- Load Compensation Reference
- Full Heat
- PC Factor

4.1 Modifying Product Settings

- 1) Press and hold the program button until “PROG” shows in the display, followed by “ENTER CODE”.
- 2) Enter code 1, 2, 3 (first 3 product buttons). “PRODUCT” and “PROGRAM” show in the displays, followed by “SELECT PRODUCT” and “-P 1-” (ex: NUG).
- 3) **Change Product Names**
Use the up and down buttons to scroll through the 40 products, or press the desired product button.
- 4) Press the right arrow button and “NAME” shows in the left display and the product (ex: NUGGETS) shows in the right display.
- 5) Press \checkmark button and the first letter in the name flashes. Press a product button and the flashing letter changes to the first letter under the product button that was pressed. For example, if product button one is pressed, the flashing letter changes to an “A”. Press the same button again and the flashing letter changes to a “B”. Press it again and flashing letter changes to a “C”. Once the desired letter shows in display, press the right arrow button to continue to next letter and repeat the procedure. Press and hold the right X button to exit Program Mode, or press the right arrow button to continue on to “COOK TIME”.
- 6) **Assign Button**
Press the right arrow button until “ASSIGN BTN” shows in the display, along with the product (ex: NUGGETS). If this product already has a product button

assigned to it, that LED will be lit. To assign other product buttons to that product, press and hold the product button for 3 seconds and that LED stays lit. To remove a product from a button, press and hold the product button with a lit LED and the LED goes out.

7) Change Times & Temperature

Press the right arrow button until "COOK TIME" shows in the display, and then use the product buttons, or the up arrow and down arrow buttons, to change the time in minutes and seconds, to a maximum of 59:59.

- 8) Press the right arrow button and "TEMP" shows in the display, along with the preset temperature on the right side of the display. Press the product buttons, or the up arrow and down arrow buttons, to change the temperature. The temperature range is 190°F (88°C) to 375°F (191°C).

9) Cook ID Change

Press the right arrow button until "COOK ID" shows in the display along with the product ID. For example, NUG would be the ID for nuggets. Use the product buttons, or the up arrow and down arrow buttons, to change the ID.

10) Alarms (1 & 2)

Press the right arrow button until "ALRM 1" shows in the left display, and an alarm time in the right display. Press the product buttons, or the up and down arrow buttons, to set an alarm. Ex., If a Cook Cycle was set at 3 minutes, and an alarm was to go off after 30 seconds into the Cook Cycle, "2:30" would be set in the display at this time. When the timer counts down to 2:30 the alarm sounds. After alarm time is set, press the right arrow button and "ALRM 2" shows in display, and a second alarm can be programmed.

11) Quality Timer (Hold Time)

Press the right arrow button until "QUAL TMR" shows in the display along with the preset holding time. Press the product buttons or the up and down arrow buttons to adjust holding time, up to 2 hours: 59 minutes.

12) A. Global Filter Tracking - Include In Filter Count

Press the right arrow button until "INCL IN FLTR CNT" flashes in display along with "YES" or "NO". Using the up or down arrow buttons, change the display to "YES" if that product's Cook Cycles are to be counted as part of the recommended filter process. Set to "NO" if it is not to be included.

B. Mixed Filter Tracking - Filter After "X" Number Of Loads

Press the right arrow button until "FILTER AFTER ..." flashes in the left display, and the number of cook cycles between filters shows in the right display. Press the product buttons or the up and down arrow buttons to change this value of 0 to 99 loads. This needs set for each product.

13) Load Compensation

Press the right arrow button until "LD COMP" shows in the display along with the load compensation value. This automatically adjusts the time to account for the size and temperature of the cooking load. Press the product buttons or the up and down arrow buttons to change this value of 0 to 20.

14) Load Compensation Reference

Press the right arrow button until "LCMP REF" shows in the display along with the load compensation average temperature (if load compensation is set to "OFF", then "___" shows in display and setting cannot be programmed). This is

the average cooking temperature for each product. The timer speeds up at temperatures above this setting and slows down at temperatures below this setting. Press the product button or the up and down arrow buttons to change this value.

15) Full Heat

Press the right arrow button until “FULL HT” shows in the display along with the full heat value in seconds, which means the heat is on as soon as a timer button is pressed, for the programmed length of time. Press the product button or the up and down arrow buttons to change this value of 0 to 90 seconds.

16) PC Factor

Press the right arrow button until “PC FCTR” shows in the display along with the proportional temperature, which helps to keep the oil from over-shooting the setpoint temperature. Press the product button or the up and down arrow buttons to change this value of 0 to 50 degrees.

NOTE:

- Use the right arrow button to go back to previous menu items.
- Press the right arrow button when finished with current product, to return to the “SELECT PRODUCT” step.
- Press and hold the program button to exit Product Program Mode

Chapter 5 Level 2 Programming

Used to access the following:

- Special Program Mode
- Clock Set
- Data Communication
- Heat Control
- Tech Mode
- Stats
- Filter Control

5.1 Special Program Mode

The Special Program Mode is used to set more detailed programming. Prior to accessing individual program modes, see the following procedure.

- 1) Press and hold the program button for five seconds until “LEVEL 2” followed by “SP PROG” and “ENTER CODE” show in the display.
- 2) Enter code 1, 2, 3, and “SP-1” “TEMP” “FORMAT” show in the displays.
NOTE: If a bad code is entered, a tone sounds and “BAD CODE” shows on the display. Wait a few seconds, the controls revert back to the cook mode, and repeat the above steps.

Table 5-1 Special Program Modes

SP-1	Temperature: Degrees Fahrenheit or Celsius
SP-2	Language: English, Greek “ΕΛΛΗΝΙΚΑ”, Russian “РУССКИЙ”, Swedish “SVENSKA”, German “DEUTSCHE”, Portuguese “PORTUG.”, Spanish “ESPAÑOL”, or French “FRANCAIS”.
SP-3	System Initialization (Factory Presets)
SP-4	Audio Volume (Loudness)
SP-5	Audio Tone (Frequency)
SP-6	Melt Cycle Selection - 1.LIQUID; 2.SOLID
SP-7	Idle Mode Enabled - YES or NO
SP-7A	Use “0” for IDLE
SP-7B	Auto Idle Minutes
SP-7C	Idle Set-point Temperature

SP-8	Filter Tracking Mode - 1.MIXED or 2.GLOBAL
SP-8A	Suggest Filter At... - 75% to 100% (MIXED)
SP-8B	Filter Lockout Enabled? - YES or NO (MIXED)
SP-8A	Left Vat Filter Cycles - 0 to 99 (GLOBAL)
SP-8B	Right Vat Filter Cycles - 0 to 99 (GLOBAL)
SP-8C	Filter Lockout Enabled? - YES or NO (GLOBAL)
SP-9	Polish Time Duration - X:XX M:SS
SP-10	Change Pad Reminder Time - XX HRS
SP-11	Clean-Out Time - XX MIN
SP-12	Clean-Out Temperature - XXX oF or C
SP-13	Cooking User IO - After Cook Cycle, display shows previous menu item or "____"
SP-14	Number of Baskets - 2-BASKETS or 4-BASKETS
SP-15	Show Cooking Indicator - YES or NO
SP-16	2nd Language: English, Greek "ΕΛΛΗΝΙΚΑ", Russian "РУССКИЙ", Swedish "SVENSKA", German "DEUTSCHE", Portuguese "PORTUG.", Spanish "ESPANOL", or French "FRANCAIS".
SP-17	2nd Audio Volume
SP-18	Energy Save Enabled? - YES or NO
SP-19	Fryer Type - GAS or ELECTRIC
SP-20	Vat Type - SPLIT or FULL
SP-21	Autolift Enabled? - NO LIFT or YES LIFT
SP-22	Bulk Oil Supply? - YES SUPL or NO SUPL
SP-23	Direct Oil Dispose? - YES DISP or NO DISP
SP-24	Serial No. of Fryer
SP-25	Change Mgr. Code- 1 = YES
SP-26	Change Usage Code - 1 = YES
SP-27	Dispose Requires Code ? - YES or NO
SP-28	Longer Fill Time Enabled - YES or NO
SP-29	Let User Exit Fill? - YES or NO

SP-30	Skip 'SKIM' Prompt? - YES or NO
SP-31	2-Stage Wash Enabled? - YES or NO

Table 5-2 Special Programming Procedures

SP-1 Temperature	<p>1. The left display flashes “SP-1” and “TEMP”, “FORMAT”. Press the up or down arrow button to choose °F or °C.</p> <p>NOTE:</p> <ul style="list-style-type: none"> • Use the left arrow button to go back to previous menu items. • Press the right arrow button when finished with current Level 2 step.
SP-2 Language	<p>1. Press and release the right arrow button until “SP-2” “LANGUAGE” flashes on the left display. Press the up or down arrow buttons to select desired language.</p>
SP-3 System Initialization	<p>1. Press and release the right arrow button until “SP-3” “DO SYSTEM INIT” flashes in the display, along with “INIT” on the right display. To reset the controls to factory default settings, press and hold the “√” button and controls count down “IN 3”, “IN 2”, “IN 1”. Once the display shows “-INIT-” and “*DONE*”, the controls are reset to factory defaults.</p>
SP-4 Audio Volume	<p>1. Press and release the right arrow button until “SP-4” “VOLUME” flashes in the left display. Press the up or down arrow buttons, or use product buttons, to adjust the speaker volume, 10 being loudest and 1 being the most quiet.</p>
SP-5 Audio Tone	<p>1. Press and release the right arrow button until “SP-5” “TONE” flashes in the left display. Press the up or down arrow button, or use product buttons, to adjust the tone of the speaker, 2000 being the maximum value and 50 being the minimum.</p>
SP-6 Melt Cycle Selection	<p>1. Press and release the right arrow button until “SP-6 MELT CYCLE SELECT” scrolls in the left display. Unless solid oil is being used in the vats, the right display should show “1.LIQUID”.</p> <p>2. If solid shortening is used, the unit must be equipped to handle solid oil. Use the up and down arrow buttons to change the right display to “2.SOLID”.</p>
SP-7 Idle Mode Enabled	<p>An Idle Mode allows the oil temperature to drop to a lower temperature when not in use. This saves on oil and utilities.</p> <p>1. Press and release the right arrow button until “SP-7” “IDLE MODE ENABLED?” flashes in the left display. Press the up or down arrow buttons to choose “YES” or “NO”.</p>

	<ol style="list-style-type: none"> 2. With "YES" in the display, press the right arrow button and "SP-7A" "USE '0' FOR IDLE" flashes on the left display. Press the up or down arrow buttons to select "YES" or "NO". If "YES" is selected, an Idle Mode can be programmed in product button 0. 3. Press the down arrow button and "SP-7B" "AUTOIDLE MINUTES" flashes in the left display. Press the up or down arrow buttons, or use the product buttons, to set the time (0 to 60 minutes) fryer stays idle before auto-idle is enabled. Ex., "30" means, if product is not cooked in that vat for 30 minutes, the control automatically cools the oil down to the idle setpoint temperature. 4. Press the right arrow button and "SP-7C" "IDLE SETPT" flashes in the left display. Press the up or down arrow buttons, or use the product buttons, to set idle temperature 200°F to 375°F (93°C to 191°C). 												
<p>SP-8 Filter Tracking Mode</p>	<p>Filter Tracking signals the operator when the oil needs filtering by counting the number of Cook Cycles between filters.</p> <ol style="list-style-type: none"> 1. Press and release the right arrow button until "SP-8" "FILTER TRACKING MODE" shows in the display. Use the up and down arrow buttons to choose either "1.MIXED" filter tracking or "2. GLOBAL" <p>NOTE:</p> <ul style="list-style-type: none"> • GLOBAL means all the products have the same number of cook cycles between filters • MIXED means each product may be set with different number of cook cycles between filters. The controls add the cycle count (see example below) and when the counts equal 1 or greater, filtering is suggested. Ex., 1 load of fish, 2 loads of french fries, a load of chicken equals 1. $1/2 + 1/8 + 1/8 + 1/4 = 1$ <table border="1" data-bbox="631 1249 1380 1459"> <thead> <tr> <th>Product</th> <th>No. Cook Cycles</th> <th>Cycle Count</th> </tr> </thead> <tbody> <tr> <td>Fish</td> <td>2</td> <td>1/2</td> </tr> <tr> <td>French Fries</td> <td>8</td> <td>1/8</td> </tr> <tr> <td>Chicken</td> <td>4</td> <td>1/4</td> </tr> </tbody> </table> <p>MIXED</p> <ol style="list-style-type: none"> 1. If MIXED is selected, press the right arrow button and SP-8A" "SUGGEST FILTER AT..." shows in the left display, and a value between 75% and 100 % shows on the right display. Press the up and down arrow buttons to change this value. The lower the value, the sooner the control recommends to filter. Ex: If set to 75%, the control suggest filtering after 3/4 of the programmed cook cycles must be completed before the control suggest filtering. 	Product	No. Cook Cycles	Cycle Count	Fish	2	1/2	French Fries	8	1/8	Chicken	4	1/4
Product	No. Cook Cycles	Cycle Count											
Fish	2	1/2											
French Fries	8	1/8											
Chicken	4	1/4											

	<ol style="list-style-type: none"> 2. Press the right arrow button and “SP-8B” “LOCKOUT ENABLED?” shows in the left display. Press the up and down arrow buttons to choose “YES or “NO”. 3. If set to “YES”, when controls suggest filtering, “FILTER LOCKOUT”/“YOU *MUST* FILTER NOW”, shows in display; more cook cycles are refused until vat is filtered. 4. Press the right arrow button and “SP-8C” “FILTER LOCKOUT AT...” shows in left display and a value between 100% and 250% shows on right display. Press the up and down arrow buttons to change this value. The lower the value, the sooner the “lockout” occurs. Ex., If set at 100%, “lockout” occurs when the cycle count reaches 1 or greater. Set at 200%, twice as many cycles are counted before “lockout” occurs. <p>GLOBAL If GLOBAL is selected, press the right arrow button.</p> <ul style="list-style-type: none"> • Split Vat <ol style="list-style-type: none"> 1. If unit is a split vat, “SP-8A” “LEFT VAT FILTER CYCLES” shows in left display, and the number of cook cycles between filters shows on right display (0 to 99). Use the up and down arrow buttons, or the product buttons, to change this value. 2. Press the right arrow button and “SP-8B” “RIGHT VAT FILTER CYCLES” shows in the left display, and the number of cook cycles between filters shows on the right display (0 to 99). 3. Press the right arrow button and “SP-8C” “FILTER LOCKOUT ENABLED?” shows in the left display. Press the up and down arrow buttons to choose “YES” or “NO”. 4. If “YES” is selected, press the right arrow button and the left display shows “SP-8D” “LEFT VAT LOCKOUT CYCLES” and the number of cook cycles before filter lockout shows on the right display (0 to 99). Use the up and down arrow buttons, or the product buttons, to change this value. 5. Press the right arrow button and left display shows “SP-8E” “RGHT VAT LOCKOUT CYCLES” and number of cook cycles before lockout shows in the right display (0 to 99). Use the up and down arrow buttons, or product buttons, to change this value. 6. Once this number of cook cycles is reached, “FILTER LOCKOUT”/“YOU *MUST* FILTER NOW”, shows in the display; more cook cycles are refused until vat is filtered. • Full Vat <ol style="list-style-type: none"> 1. If unit is a full vat, “SP-8A” and “FULL VAT FILTER CYCLES” shows in the left display, and the number of cook cycles between filters shows on the right display (0 to 99).
--	---

	<p>Use the up and down arrow buttons to choose “YES” or “NO”.</p> <ol style="list-style-type: none"> 2. Press the right arrow button and “SP-8B” “FILTER LOCKOUT ENABLED?” shows in the left display. Press the up and down buttons to choose “YES” or “NO”. 3. If set to “YES”, press the right arrow button and the left display shows “SP-8C” “FULL VAT LOCKOUT CYCLES” and the number of cook cycles before filter lockout shows on the right display (0 to 99). Use the up and down arrow buttons, or product buttons, to change this value. 4. Once this number of cook cycles is reached, “FILTER LOCKOUT”/“YOU *MUST* FILTER NOW”, shows in the display; more cook cycles are refused until vat is filtered.
SP-9 Polish Duration	<ol style="list-style-type: none"> 1. Press and the release the right arrow button until “SP-9 POLISH TIME” flashes in the left display. Press the up and down arrow buttons, or the product buttons, to change the polish time, from 0 to 10 minutes.
SP-10 Change Filter Pad Reminder Time	<ol style="list-style-type: none"> 1. Press and release the right arrow button until “SP-10 CHANGE PAD REMINDER” flashes in the left display. Press the up and down arrow buttons, or the product buttons, to change the time from 0 to 100 hours.
SP-11 Clean-Out Time	<ol style="list-style-type: none"> 1. Press and release the right arrow button until “SP-11 CLEAN-OUT TIME” flashes in left display. Press the up and down arrow buttons, or the product buttons, to change the time, from 0 to 99 minutes.
SP-12 Clean-Out Temperature	<ol style="list-style-type: none"> 1. Press and release the right arrow button until “SP-12 CLEAN-OUT TEMP” flashes in the left display. Press the up and down arrow button, or the product buttons, to change the temperature, from 0 to 195°F (-18 to 90°C).
SP-13 Cooking User IO	<ol style="list-style-type: none"> 1. Press and release the right arrow button until “SP-13 COOKING USER IO” flashes in the display. Press the up and down arrow buttons to choose “SHOWPREV” or “SHOW- - - -”. 2. Setting SP-13 to “SHOWPREV” means after a cook cycle, the display shows the last menu item cooked. “SHOW- - - -” means after a cook cycles “- - - -” shows in the display and a menu item needs selected before starting the next cook cycle.
SP-14 Number Of Baskets	<ol style="list-style-type: none"> 1. Press and release the right arrow button until “SP-14 NUMBER OF BASKETS” flashes in the left display. Press the up and down arrow buttons to choose 2 or 4 baskets per well.

SP-15 Cooking Indicator	<ol style="list-style-type: none"> 1. Press and release the right arrow button until “SP-15 SHOW COOKING INDICATR” flashes in the left display. Press the up or down arrow buttons to choose “YES” and during a cook cycle “*” shows which timer is counting down. Choose “NO” and “*” will not shows during a cook cycle
SP-16 2nd Language	<ol style="list-style-type: none"> 1. Press and release the right arrow button until “SP-16 2ND LANGUAGE” flashes in the left display. Press the up and down arrow buttons to selected the desired 2nd language. NOTE: By setting a 2nd language in the controls, 2 languages can now be chosen by pressing the program button during normal operation. One language shows in the right display. Pressing the √ button selects the language in the display.
SP-17 2nd Volume	<ol style="list-style-type: none"> 1. Press and release the right arrow button until “SP-17 2ND VOLUME” flashes in the left display. Press the up and down arrow buttons, or product buttons, to select the desired 2nd volume. NOTE: Be setting a 2nd volume in the controls, 2 volumes can now be chosen by pressing the program button twice during normal operation. One volume setting shows in the left display (NONE to 10; 10 being the loudest) and the seconds volume shows in the right display. To select the volume, press the √ button under the desired volume.
SP-18 Energy Save Mode	<ol style="list-style-type: none"> 1. Press and release the right arrow button until “SP-18 ENERGY SAVE ENABLED?” flashes in the left display. press the up and down arrow buttons to choose “YES” or “NO”. 2. If set to “YES”, during times of non-use, the fryer automatically starts an Energy Save Mode, which turns off the blowers. Then once a product is selected to start a cook cycles, the blowers and heat come back on. If set to “NO”, the blowers are on constantly.
SP-19 Fryer Type	<ol style="list-style-type: none"> 1. Press and release the right arrow button until “SP-19 FRYER TYPE” flashes in the left display. Press the up or down buttons to choose “GAS” or “ELEC”.
SP-20 Vat Type	<ol style="list-style-type: none"> 1. Press and release the right arrow button until “SP-20 VAT TYPE” flashes in the left display. Press the up and down arrow buttons to choose “SPLIT” or “FULL”.
SP-21 Auto-Lift Enabled	<ol style="list-style-type: none"> 1. Press and release the right arrow button until “SP-21 AUTOLIFT ENABLED?” flashes in the left display. Press the up and down arrow buttons to choose “YES LIFT” or “NO LIFT”. 2. If fryer is fitted with the auto-lift option, SP-21 must be set to “YES LIFT”, otherwise, set SP-21 to “NO LIFT”.

<p>SP-22 Bulk Oil Supply</p>	<ol style="list-style-type: none"> 1. Press and release the right arrow button until "SP-22 BULK OIL SUPPLY?" flashes in the left display. Press the up and down arrow buttons to choose "YES SUPL" or "NO SUPL". 2. Set to "YES" if the oil is pumped into the vat from an outside oil reservoir. Otherwise, set SP-22 to "NO".
<p>SP-23 Bulk Oil Disposal</p>	<ol style="list-style-type: none"> 1. Press and release the right arrow button until "SP-23 BULK OIL DISPOSE?" flashes in the left display. Press the up and down arrow buttons to choose "YES DISP" or "NO DISP". 2. Set to "YES DISP" if the oil is pumped from the vats to an outside oil reservoir when discarding the oil. Otherwise, set SP-23 to "NO DISP".
<p>SP-24 Serial Number Log</p>	<ol style="list-style-type: none"> 1. Press and release the right arrow button until "SP-24 S/N √EDIT" flashes in the displays, along with the serial number of the unit. NOTE: This serial number should match the serial number on the data plate, on the doors. If not, it can be recorded.
<p>SP-25 Program Code Change</p>	<p>This allows the operator to change the program code (factory set at 1, 2, 3) used to access Product Programming and Level 2 Program Mode.</p> <ol style="list-style-type: none"> 1. Press and release the right arrow button until "SP-25 CHANGE MGR CODE? 1=YES" flashes in the display. Press product button 1 and "ENTERNEWCODE, P=DONE, I=QUIT" scrolls through the display. Press the product buttons for new code. 2. If satisfied with the code, press the program button and "REPEAT NEW CODE, P=DONE, I=QUIT" shows in display. Enter the same code you previously entered. 3. If satisfied with code, press the program button and "CODE CHANGED*" shows in display. 4. If not satisfied with code, press the info button and "*CANCEL*" shows in display, then reverts back to "SP-25" "CHANGE MGR CODE? 1=YES". Now the above steps can be repeated.
<p>SP-26 Usage Code Change</p>	<p>This allows the operator to change the reset usage code (factory set at 1, 2, 3) to reset the usage amounts of each product. See in Information Mode.</p> <ol style="list-style-type: none"> 1. Press and release the right arrow button until "SP-26 CHANGE USAGE CODE? 1=YES" flashes in the display. Press product button 1 and "ENTER NEW CODE, P=DONE, I=QUIT" scrolls through display. Press product buttons for new code. 2. If satisfied with code, press the program button and "REPEAT NEW CODE, P=DONE, I=QUIT" shows in the display. Enter the previously entered code.

	<ol style="list-style-type: none"> If satisfied with code, press the program button, “*CODE CHANGED*” shows in display. If not satisfied with code, press the info button and “*CANCEL*” shows in display the reverts back to “SP-26” “CHANGE USAGE CODE? 1=YES”. Now the above steps can be repeated.
SP-27 Dispose Requires Code?	<ol style="list-style-type: none"> Press and release the right arrow button and “SP-27 DISPOSE REQUIRES CODE?” flashes in the left display. Press the up and down arrow buttons to choose “YES” or “NO”. If set to “YES”, code 1, 2, 3, must be entered to discard the oil from the vat using the Dispose Mode.
SP-28 Longer Fill Time	<ol style="list-style-type: none"> Press and release the right arrow button until “SP-28 LONGER FILL TIME ENABLED?” flashes in the left display. Press the up and down buttons to choose “YES” or “NO”.
SP-29 Let User Exit Fill	<ol style="list-style-type: none"> Press and release the right arrow button until “SP-29 LET USER EXIT FILL” flashes in the left display. Press the up and down arrow buttons to choose “YES” or “NO”. If “YES” is chosen, the user can exit the Express Filter™ fill operation.
SP-30 Skip “SKIM” Prompt	<ol style="list-style-type: none"> Press and release the right arrow button until “SP-30 SKIP ‘SKIM’ PROMPT?” flashes in the left display. Press the up and down arrow buttons to choose “YES” or “NO”.
SP-31 2-Stage Wash Enabled	<ol style="list-style-type: none"> Press and release the right arrow button until “SP-31 2-STAGE WASH ENABLED?” flashes in the left display. Press the up and down arrow buttons to choose “YES” or “NO”.

5.2 Do Not Disturb

Time periods of peak operations during which the “FILTER NOW?” message will not appear, may be programmed into the fryer. There are three groupings of days - Monday thru Friday (M-F), Saturday (SAT), and Sunday (SUN). Within each day grouping, up to 4 time periods (M-F 1 thru M-F 4, SAT 1 thru SAT 4, and SUN 1 thru SUN 4) may be programmed. A time period may be anywhere from 1 to 180 minutes in length.

- Press and hold the program button for 5 seconds until “LEVEL 2” “SP PROG” “ENTER CODE” shows in the display.
- Press the program button once more and “DO NOT DISTURB” “ENTER CODE” flash in the left display.
- Using the product buttons, enter code 1, 2, 3.
- “DO NOT DISTURB ENABLED?” flashes in the left display and “YES” or “NO” appears in the right display. Press the up and down buttons to choose “YES” or “NO”.

- 5) Press the program button and "M-F 1" shows in the left display and the time flashes in the right display. Press the up and down arrow buttons, or product buttons, to change the time.
- 6) Press the program button and "M-F 1" shows in the left display and "A" or "P" flashes in the right display. Use the up and down arrow buttons to choose AM or PM.
- 7) Press the program button and "M-F 1" shows in the left display and far right character display flashes. Press the product buttons to enter amount of time (up to 180 minutes) during which filtering will be inhibited, after time entered in step 5.
- 8) Press the program button to move to the next timer period, M-F 2.
- 9) Repeat steps 5, 6, 7, and 8 for other desired time periods.

5.3 Clock Set

- 1) Press and hold the Program button for 5 seconds until "LEVEL 2" "SP PROG" "ENTER CODE" shows in the display.
- 2) Press the program button again and "CLK SET" "ENTER CODE" flashes in the left display.
- 3) Enter code 1, 2, 3.
- 4) "CS-1 ENTER DATE MM-DD-YY" flashes in the left display. Use the product button to set the date in the right display.
- 5) Press the right arrow button and "CS-2 ENTER TIME" flashes in the left display and the time flashes in the right display. Press the up and down arrow buttons, or product buttons, to change the time.
- 6) Press the right arrow button and "CS-2 ENTER TIME" flashes in the left display and "AM" or "PM" flashes in the right display. Use the up and down arrow buttons to choose "AM" or "PM".
- 7) Press the right arrow button and "CS-3 TIME FORMAT" flashes in the left display and "12-HR" or "24-HR" shows in the right display. Use the up and down arrow buttons to choose a 12-hour time format or a 24-hour time format.
- 8) Press the right arrow button and "CS-4 DAYLIGHT SAVING TIME" flashes in the left display. Use the up and down arrow buttons to choose daylight saving time for your area: 1.OFF; 2.US (2007 & after); 3.EURO; or 4.FSA (US before 2007).
- 9) Press and hold the program button to exit.

5.4 Data Logging, Heat Control, Tech, Stat, & Filter Control Modes

The Data Logging, Heat Control, Tech, Stat and Filter Control Modes are advanced diagnostic and program modes, mainly for Henny Penny use only. For more information on these modes, contact the Service Department at 1-800-417- 8405 or 1-937-456-8405.

5.5 Tech Mode

The TECH Mode has self-diagnostic information, which can be used by certified technicians for troubleshooting purposes. The Tech Modes are listed in [Table 5-3 Tech Modes, page 31](#) and explained further in [Table 5-4 Tech Mode Details, page 32](#).

NOTE: Not all Tech Mode functions are discussed in this section. To ensure proper operation of fryer, please consult Henny Penny Corp. before changing any of these settings. For more information on these functions, contact the Service Department at 1-800-417- 8405, or 1-937-456-8405.

To enter Tech Mode:

- 1) Press and hold the program button for 5 seconds until “LEVEL 2”, followed by, “SP PROG” and “ENTER CODE” show in the display.
- 2) Press the program button 4 times and “TECH” and “ENTER CODE” flash in the left display.
- 3) Enter code 1, 1, 2, 2, 1, 1, 2, 2 (first 2 product buttons).
- 4) “T-1 SOFTWARE” flashes in the left display and “EV-ELITE” shows in the right display. Use the up and down arrow buttons to select the steps.

NOTE:

- If a bad code is entered, a tone sounds and “BAD CODE” shows on the display. Wait a few seconds, the controls revert back to the cook mode, and repeat the above steps.
- Press and hold the program button at anytime to return to normal operation.

Table 5-3 Tech Modes

Program Code	Description
T-1	Software
T-2	Fryer Type (Gas or Elec.)
T-3	Push Button Test
T-4	All On Display Test
T-5	Display Segment Test
T-6	Display Digits Test
T-7	Display Decimal Point Test
T-8	LED's Test
T-9	Left Temp. Probe Calibration & Offset
T-10	Left Level 1 Probe Calibration & Offset
T-11	Left Level 2 Probe Calibration & Offset
T-12	Right Temp. Probe Calibration & Offset
T-13	Right Level 1 Probe Calibration & Offset

Program Code	Description
T-14	Right Level 2 Probe Calibration & Offset
T-15	CPU Control Temp. Calibration/Offset/Highest
T-16	View A - D Channel
T-17	Digital Inputs
T-18	AIF Info
T-19	Outputs Test
T-20	Pumps & Valves Test
T-21	Recovery Test Limit
T-22	Drain Light Stay On?
T-23	Heat Err Enabled?
T-24	Change Tech Code?
T-25	Total Initialization

Table 5-4 Tech Mode Details

Program Code	Description
T-1 Software	<ul style="list-style-type: none"> • Press product button 1 to view HP Part No. of eprom. • Press product button 2 to view software ID. • Press product button 3 to view software version.
T-2 Fryer Type	Gas or Electric
T-3 Push-Button Test	<ol style="list-style-type: none"> 1. Press any of the control buttons to test operation. You should hear a beep, and the LED should light and/or a display.
T-4 All On Display Test	<ol style="list-style-type: none"> 1. Press any of the product buttons and all the LEDs and display segments should light.
T-5 Segments Test	<ol style="list-style-type: none"> 1. Press timer button 1 to view the different segments of the display characters.
T-6 Digits Test	<ol style="list-style-type: none"> 1. Press timer button 1 to view all segments of each digit across the displays.
T-7 Decimal Points Test	<ol style="list-style-type: none"> 1. Press timer button 1 to view all decimal points across the displays.

Program Code	Description
T-8 LED's Test	1. Press timer button 1 to view each LED across the control panel.
T-17 Digital Inputs - HDE	<p>1. Press the down arrow button and an underscore (“_”) indicates the input is not presently detected. A Checkmark (“√”) indicates the signal is detecting a normal input. A blinking (“X”) indicates the signal is presently detected, but is detected as a half-wave (partially failed) input.</p> <p>H = HIGH LIMIT - If “H” is present, the high limit is good. If “-” shows then the high limit is tripped out (overheated) or disconnected.</p> <p>D = DRAIN SWITCH - If “D” is present, the drain handle (when applicable) is closed. If “-” shows then the drain is open or the switch is faulty.</p> <p>E = Element switch - If “E” is present, the element switch is good. If “-” shows in the display, the element is in the upright position, or the switch is faulty.</p> <p>NOTE: The H, D, E signals above are wired in series. The first signal missing out of this sequence generally causes all signals to the right of it to be missing as well.</p>
T-18 AIF Info (AIF PCB Communicat- ing With Control PCB?)	An “AIF √” means normal communications between the AIF PCB and the control PCB. “AIF X” means a problem with the communications between the PCBs.

Program Code	Description
T-19 Outputs	<p>S = SAFETY CONTACTOR - Press product button 6 to turn off and on the safety (primary) contactor.</p> <p>H = HEAT CONTACTOR - Press product button 7 to turn off and on the heat contactor. (Product button 1 turns off and on the safety (primary) contactor for the left vat of a split vat fryer, and product button 2 turns off and on the heat contactor.)</p>
T-20 Pumps & Valves	<ol style="list-style-type: none"> 1. Press the down arrow button and "LIGHTS" "DLT_" shows in displays. 2. Press product button 1 and left Filter Beacon® lights (split vats) and press product button 2 and right Filter Beacon® lights (display shows "DLTo" when on). 3. Press the down arrow button and "VALVES" "DcRc" shows in displays. 4. Press product button 7 to open and close the return valve. "DcRc" means valve is closed, "DcRo" means valve is open. (Driven by the control board.) 5. Press the down arrow button and "DISCARDc" and "JIBFILLc" shows in the displays. (Driven by the AIF board) 6. Press product button 1 to open and close the RTI discard valve (display shows "DISCARDo" when open) 7. Press product button 2 to open and close the RTI JIB fill valve (display shows "JIBFILLo" when open) 8. Press the down arrow button and "PUMP FP_" and "JP_ NP_" shows in the displays. (Driven by the AIF board) 9. Press product button 1 to turn off and on the filter pump (display shows "FP*" when on) 10. Press product button 2 to turn off and on the JIB pump (display shows "JP*" when on) 11. Press product button 3 to turn off and on the new oil pump (if available - display shows "NP*" when on) 12. Press the down arrow button and "AIF REQ" and "RQ=Y OK=Y" shows in the displays. REQ=Y" means that this particular control is currently requesting control of the AIF Board outputs. "OK=Y" means that the AIF Board has granted this control the authority to control the AIF Board outputs. 13. Press the down arrow button and "FILR IN" and "USE BY 1(ex)" shows in the displays. These displays shows which controls are using the filtering system. "USE = 0" = not in use "USE = 7" = used by AIF "USE = 1 to 5" = used by control PCB

Program Code	Description
	<p>14. Press the down arrow button and "CPU POSN" and "1 OF 3(ex)" shows in the displays. These displays shows which controls are plugged into which port on the AIF board. For example, the left control should be plugged into port 1, and on a 3 control fryer, shows "1 OF 3" on the display. If the right control is unplugged, then the left control would show "1 OF 2" instead of "1 OF 3".</p> <p>15. Press the down arrow button and "INP E_P_" and "JL_Rx DF_" shows in the displays. E = Stop button P = Drain Pan JL = JIB R = RTI DT = Discard Tank Ex = E-Stop pressed Px = drain pan is missing Jx = JIB oil level is low Rx = RTI System NOT Detected DTx = tank full</p> <p>16. Press the down arrow button and "OUT F_J_" and "N_DI_oJF_" shows in the displays. AIF Board Outputs: Current outputs status from AIF board. F = Filter Pump (Fx = Filter pump is on) J = JIB Pump (Jx = JIB pump is on) N = New Oil Pump (if present) (Nx = RTI new oil pump on) DI = Discard Valve (if present) (Dlo = Disc. valve open/Dlc= closed) JF = JIB Fill Valve (JFo = JIB fill valve open/JFc=closed)</p> <p>17. Press the down arrow button and "REQ F_J_" and "N_DI_JF_" shows in the displays. AIF Board Outputs Requested by the Control Board: Current outputs status from AIF board. F = Filter Pump (Fx = Filter pump is on) J = JIB Pump (Jx = JIB pump is on) N = New Oil Pump (if present) (Nx = New oil pump on) DI = Discard Valve (if present) (Dlo = Disc. valve open/Dlc= closed) JF = JIB Fill Valve (JFo = RTI JIB fill valve open/JFc=closed)</p>

5.6 Stats Mode

This mode allows a technician to view advanced information on the operation of the fryer and controls.

- 1) Press and hold the program button for 5 seconds until “LEVEL 2”, followed by, “SP PROG” and “ENTER CODE” show in the display.
- 2) Press the program button 5 times and “STATS” and “ENTER CODE” flash in the left display.
- 3) Enter code 1, 1, 2, 2, 1, 1, 2, 2 (first 2 product buttons).
- 4) “ST-1 STATS LAST RESET ON...” flashes in the left display and the date shows in the right display. Use the up and down arrow buttons to select the steps.

NOTE:

- If a bad code is entered, a tone sounds and “BAD CODE” shows on the display. Wait a few seconds, the controls revert back to the cook mode, and repeat the above steps.
- Press and hold the program button at anytime to return to normal operation.

Table 5-5 Stat Modes

Program Code	Description
ST-1	Stats Last Reset Date
ST-2	Fryer Total Running Hours
ST-3	Left Vat Melt Cycle Hours
ST-4	Left Vat Cook Cycle Hours
ST-5	Left Vat Idle Hours
ST-6	Right Vat Melt Cycle Hours
ST-7	Right Vat Cook Cycle Hours
ST-8	Right Vat Idle Hours
ST-9	Power-Ups Count
ST-10	Error Counts
ST-11	Left Vat Heat On Hours
ST-12	Right Vat Heat On Hours
ST-13	Highest Left Vat Oil Temperature
ST-14	Highest Right Vat Oil Temperature
ST-15	Highest CPU Temperature
ST-16	System RAM Fade Count
ST-17	Cook RAM Fade Count

Program Code	Description
ST-18	Product RAM Fade Count
ST-19	Stat RAM Fade Count
ST-20	RAM Data Error Count
ST-21	Data Total Loss Count
ST-22	User Initialization Count
ST-23	Automatic Initialization Count
ST-24	Cooks Count per Product
ST-25	Cook Cycle Stop Counts
ST-25A	Number Of Stops In First 30 Seconds
ST-25B	0
ST-25C	0
ST-25D	Complete Cook Cycles Counted
ST-26	Reset All Stats

Chapter 6 Maintenance

6.1 Introduction

This section provides checkout and replacement procedures, for various parts of the fryer. Before replacing any parts, refer to the Troubleshooting Section to aid you in finding the cause of the malfunction.

6.2 Maintenance Hints

- 1) A multimeter will help you to check the electric components.
- 2) When the manual refers to the circuit being closed, the multimeter should read zero unless otherwise noted.
- 3) When the manual refers to the circuit being open, the multimeter should read infinity.



WARNING Do not move the fryer with hot oil in the vat or filter pan. Severe burns can result from splashing hot oil.

6.3 Preventative Maintenance

To ensure a long life of the fryers and their components, regular maintenance should be performed. Refer to the table below.

Table 6-1 Preventative Maintenance

Procedure	Frequency
Filtering of shortening. See 3.11 Filtering The Shortening of Operator's Manual.	Daily.
Changing the filter pad. See 3.16 Changing The Filter Pad of Operator's Manual.	Daily.
Lubricate filter pan O-rings. See 3.19 Check/ Replace Drain Pan O-Rings of Operator's Manual.	Every filter pad change.
Lubricate EEE-141 oil reservoir O-rings	When reservoir is removed.
Changing of oil.	When oil smokes, foams up violently, or tastes bad.
Cleaning the vat. See 3.18 Clean-Out Mode of Operator's Manual.	Every change of oil.

Procedure	Frequency
Inspect filter pan O-rings. See 3.19 Check/ Replace Drain Pan O-Rings of Operator's Manual.	Quarterly.
Inspect EEE-141 reservoir O-rings. See 3.10 Model EEE-141 Oil Reservoir of Operator's Manual.	Quarterly.

6.4 Control Panel & Menu Card Replacement

Should the control panel become inoperative, or the menu card needs changed, follow these instructions:

- 1) Remove electrical power supplied to the vat.



WARNING To avoid electrical shock or property damage, move the power switch to OFF and disconnect main circuit breaker, or unplug cord at wall receptacle.

- 2) Remove the two screws securing the control panel. See [Figure 6-1 Control Panel Screws, page 40](#).



01180135

Figure 6-1 Control Panel Screws

- 3) Pull the top of the panel down, allowing the panel to be supported by the 2 brackets in the slots in the control shroud. (If changing control panel, continue onto step 5.) See [Figure 6-2 Lowered Control Panel, page 41](#).

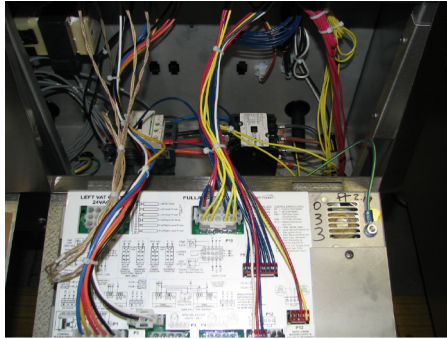

01180136

Figure 6-2 Lowered Control Panel

- 4) If changing the menu card, loosen the tape securing the menu card at the bottom side of the control panel and pull menu card from panel. Carefully slide changed menu card back into slot in panel and secure with tape. See [Figure 6-3 Removing Menu Card](#), page 41.

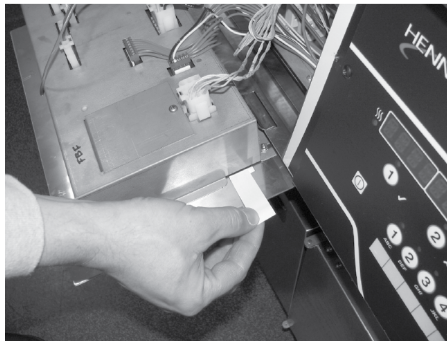

01180137

Figure 6-3 Removing Menu Card

- 5) Unplug the connectors going to the control board. See [Figure 6-4 Unplugging Control Board Connectors](#), page 42.

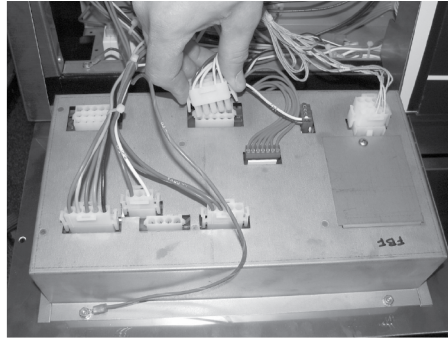

01180138

Figure 6-4 Unplugging Control Board Connectors

- 6) Install a new control panel in reverse order.

6.5 High Temperature Limit Control

This is a safety, manual reset control, which senses the temperature of the oil. If the oil temperature exceeds 425°F (218°C), this switch opens and shuts off the heat to the vat. When the temperature of the oil drops to a safe operation limit, manually reset the control by pressing the reset button.

The reset button is located in the hinge of the element. Use a small screwdriver or Allen wrench, gently push it into the hole in the heating element hinge; if high limit does not reset, high limit must be replaced. If high limit resets, the oil starts heating. See [Figure 6-5 Resetting High Limit](#), page 42.



01180139

Figure 6-5 Resetting High Limit

6.5.1 Checkout



WARNING

To avoid electrical shock or property damage, move the power switch to OFF and disconnect main circuit breaker, or unplug cord at wall receptacle.

NOTE: The oil temperature must be below 380°F (193°C) to accurately perform this check.

- 1) Remove control panel and hinge it down.
- 2) Referring to the decal on the rear of the control panel, locate P9 connector (left vat-split vat) or P10 connector (full or right vat).
- 3) Attempt to reset the high limit and then pull the connector from the board and check for continuity between the 2 appropriate pins. If the circuit is open then continue replacement procedure. (If the circuit is closed, the high limit is not defective). See [Figure 6-6 High Limit Continuity Check](#), page 43.

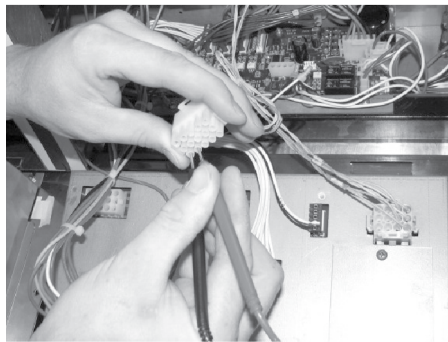

01180140

Figure 6-6 High Limit Continuity Check

6.5.2 Replacement

If the tube is broken or cracked, the control opens, shutting off electrical power. The control cannot be reset.

- 1) Using a crosshead screwdriver, or screw gun, remove the rear panel (9 screws).
- 2) Using 3/8" wrench or socket, remove the 2 acorn nuts securing bracket to unit. See [Figure 6-7 Removing High Limit Bracket Acorn Nuts](#), page 43.

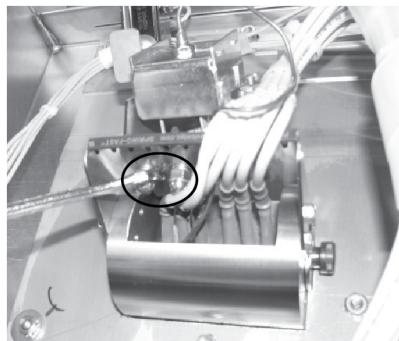

01180141

Figure 6-7 Removing High Limit Bracket Acorn Nuts

- 3) Using a crosshead screwdriver, remove the 2 screws securing the high limit to the bracket. See [Figure 6-8 Removing High Limit From Bracket, page 44](#).

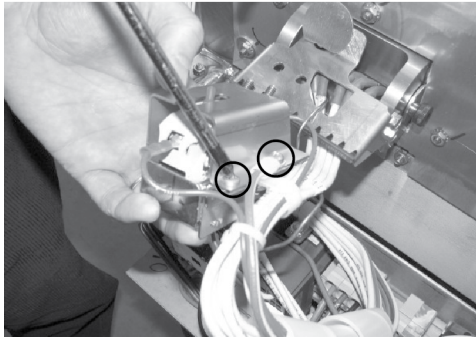

01180142

Figure 6-8 Removing High Limit From Bracket

- 4) Use the lift tool and lift the hinged element from the vat. See [Figure 6-9 Lifted Heating Element, page 44](#).



01180143

Figure 6-9 Lifted Heating Element



CAUTION

Avoid putting the lift tool in the center of the elements, at the same area as the high limit bulb, or damage to the high limit could result.

- 5) Pull the high limit from the bracket, pull back the cardboard protector, and remove the two electrical wires from the high limit control. See [Figure 6-10 Removing High Limit Wires, page 45](#).

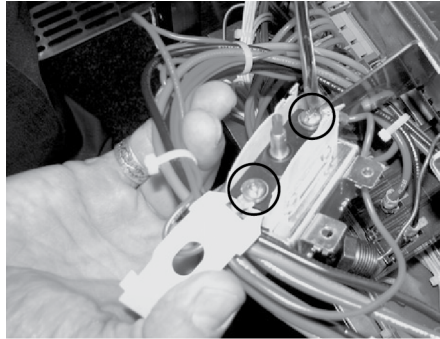

01180144

Figure 6-10 Removing High Limit Wires

- 6) Pull-out on the drain valve knob and drain the oil from the vat. See [Figure 6-11 Drain Valve Open](#), page 45.



01180117

Figure 6-11 Drain Valve Open

- 7) While holding the top-side capillary bracket, use a crosshead screwdriver and remove the screws securing the capillary bulb to the lower element bracket. Remove both front and rear capillary brackets. See [Figure 6-12 Removing Capillary Bracket Screws](#), page 46.

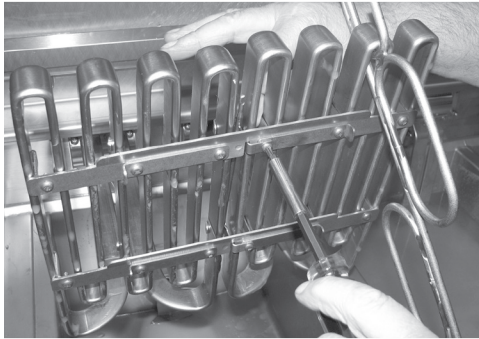

01180145

Figure 6-12 Removing Capillary Bracket Screws

- 8) Using a crosshead screwdriver, remove the screws securing the capillary bulb to the upper element brackets. See [Figure 6-13 Removing Upper Element Bracket Screws](#), page 46.

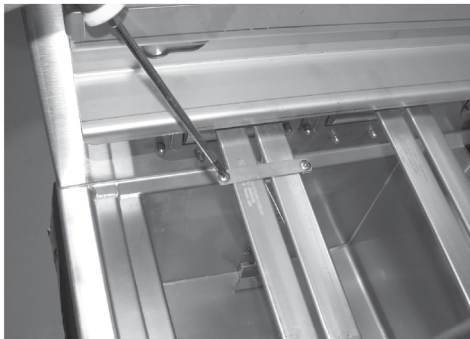

01180146

Figure 6-13 Removing Upper Element Bracket Screws

- 9) Remove high limit bulb from element and carefully straighten the capillary tube and pull the high limit control from the rear of the unit. See [Figure 6-14 Removing High Limit Bulb](#), page 47.

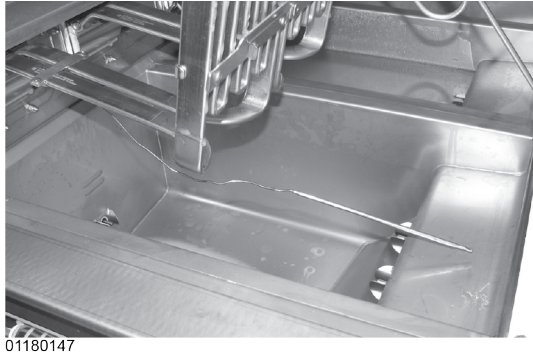

Figure 6-14 Removing High Limit Bulb

NOTE:

- It's important not to damage the capillary bulb when removing or installing the high limit from the unit. Undamaged high limits returned for warranty can be evaluated for cause of failure.
- Capillary bulbs or tubes damaged during installation causes high limit to fail prematurely. See [Figure 6-15 Damaged Capillary Tube](#), page 47.



Figure 6-15 Damaged Capillary Tube

- 10) Insert new high limit capillary through hole in rear of fryer and slide high limit into bracket and then secure with the 2 screws.
- 11) Slide bracket and high limit assembly into place, making sure a 1/8" (2-3mm) gap remains between the red high limit button and the reset place, and then secure with the 2 acorn nuts removed in step 3. See [Figure 6-16 High Limit Actuator Plate](#), page 48.

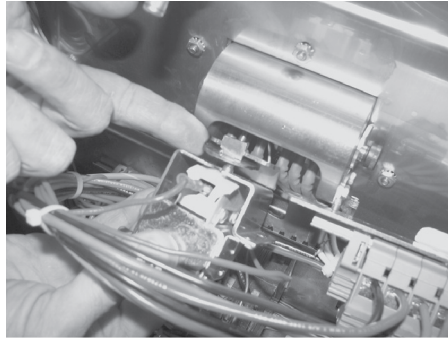

01180149

Figure 6-16 High Limit Actuator Plate

- 12) Carefully slide capillary bulb up through the element, from the rear of the elements. See [Figure 6-17 Pulling Out Capillary Bulb, page 48](#).



01180150

Figure 6-17 Pulling Out Capillary Bulb

- 13) Using the capillary brackets removed in step 3 (see below), attach the capillary to the lower brackets, aligning the capillary so it does NOT touch the element. See [Figure 6-18 Capillary Installation Side View, page 48](#).

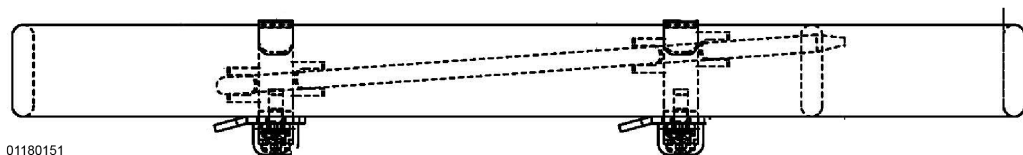

01180151

Figure 6-18 Capillary Installation Side View

- 14) Secure the capillary to the upper brackets. See [Figure 6-19 Reattach Upper Element Brackets, page 49](#).

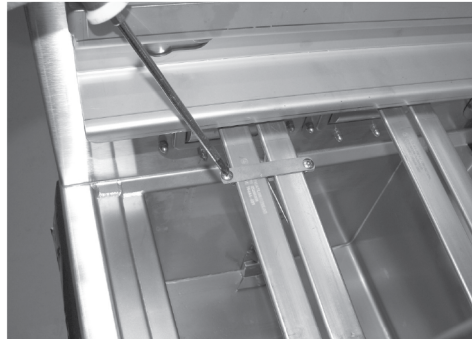

01180146

Figure 6-19 Reattach Upper Element Brackets

- 15) Replace rear cover and reconnect power to vat.
- 16) Lower element back into vat and close drain. Fill vat by pressing and holding the filter button until *FILTER**MENU* shows in the display. Then once "1. EXPRESS FILTER" shows in the display, press the right arrow button 4 times until "5.FILL FROM PAN" shows in the display. Press ✓ button and "PUMP" "EXIT" shows in the display. Press ✓ button again, and oil fills vat. Once vat is full, press X twice to return to normal operation.

6.6 Breakers

There are 4 breaker on the electric fryers. To reset the breaker, open the left door and locate breakers behind drain knob plate. Push on the plunger on the breaker to reset. See [Figure 6-20 Breakers, page 49](#).

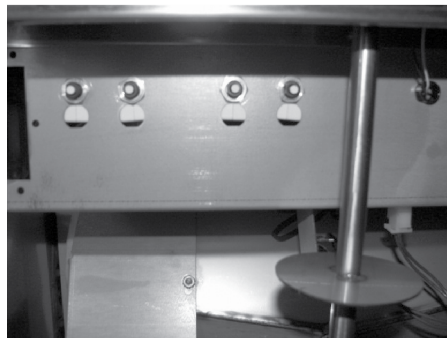

01180152

Figure 6-20 Breakers



WARNING To avoid electrical shock or property damage, move the power switch to OFF and disconnect main circuit breaker, or unplug cord at wall receptacle.

6.6.1 Checking Procedure for Breaker

- 1) Remove the left control panel and pull the wires from the breaker. Using a multimeter or continuity light, check across the terminals. The circuit should be closed. If not, replace the breaker (HP# EF02-125).
- 2) To replace breaker, remove left control panel and pull wires from breaker. See [Figure 6-21 Removing Breaker Wires, page 51](#).

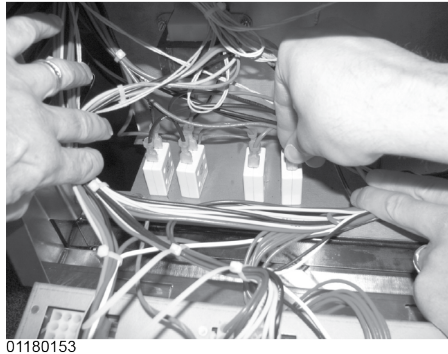

Figure 6-21 Removing Breaker Wires

- 3) Use a 9/16" wrench and loosen the nut securing the breaker from underneath and then pull the breaker from the control panel area.

6.7 Main Power Switch

This is a covered rocker switch, which in the ON position, sends power to all the controls and filter motor.



WARNING To avoid electrical shock or property damage, move the power switch to OFF and disconnect main circuit breaker, or unplug cord at wall receptacle.

- 1) Remove right side panel.
- 2) Label and remove wires from the switch. See [Figure 6-22 Removing Main Power Switch Wires, page 52](#).

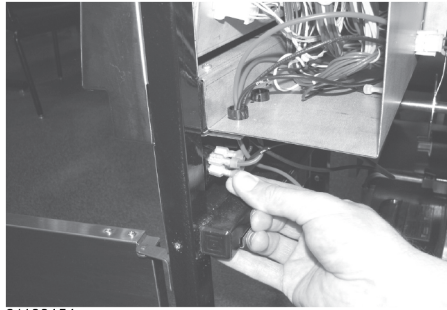

01180154

Figure 6-22 Removing Main Power Switch Wires

- 3) From the inside of the control area, squeeze in on the tabs on the back of the switch and push the switch out the front of the control area. See [Figure 6-23 Removing Power Switch, page 52](#).



01180155

Figure 6-23 Removing Power Switch

6.7.1 Checkout

- 1) Check across the two sets of terminals of the switch for continuity. With the switch in the ON position, the circuit should be closed. With the switch in the OFF position, the circuit should be open.
- 2) If the switch is found to be defective, replace it by connecting the wires to it (as labeled) and push new switch into place.

6.8 Temperature Probe Replacement

The temperature probe relays the actual shortening temperature to the control. If it becomes disabled, “E-6” shows in the display. Also, if the temperature is out of calibration more than 10°F, or 10°C, the temperature probe should be replaced. (See Section 5-4. TECH MODE for probe calibration steps.)

An Ohm check can be performed also. Refer to [Table 6-2 RTD Resistance Chart, page 53](#), and see [6.8.1 Checkout, page 53](#).

Table 6-2 RTD Resistance Chart

°F	°C	Resist- ance Ohms	°F	°C	Resist- ance Ohms	°F	°C	Resist- ance Ohms
50	10.00	1039.02	190	87.78	1338.57	325	162.78	1620.77
60	15.56	1060.65	200	93.33	1359.69	330	165.56	1631.09
70	21.11	1082.24	210	98.89	1380.79	340	171.11	1651.72
80	26.67	1103.80	212	100.00	1385.00	350	176.67	1672.31
90	32.22	1125.32	220	104.44	1401.84	360	182.22	1692.86
100	37.78	1146.81	230	110.00	1422.86	365	185.00	1703.13
110	43.33	1168.26	240	115.56	1443.85	370	187.78	1713.38
120	48.89	1189.67	250	121.11	1464.79	380	193.33	1733.87
130	54.44	1211.05	260	126.67	1485.71	390	198.89	1754.31
140	60.00	1232.39	270	132.22	1506.58	400	204.44	1774.72
150	65.56	1253.70	280	137.78	1527.43	410	210.00	1795.10
160	71.11	1274.97	290	143.33	1548.23	420	215.56	1815.44
170	76.67	1296.20	300	148.89	1569.00	430	221.11	1835.74
180	82.22	1317.40	310	154.44	1589.73	440	226.67	1856.01
185	85.00	1327.99	320	160.00	1610.43			

6.8.1 Checkout



WARNING To avoid electrical shock or property damage, move the power switch to OFF and disconnect main circuit breaker, or unplug cord at wall receptacle.

- 1) Remove control panel and hinge it down.
- 2) Referring to the decal on the rear of the control panel, locate the 12-pin probe connector in the upper, right-hand corner. (An ohm chart is also shown on the decal.)

- 3) Pull the connector from the panel and using a multimeter, take an ohm reading on the appropriate Oil Temp pins. If ohm reading is significantly different than the chart, continue with replacement instructions. See [Figure 6-24 Temperature Probe Connector Check](#), page 54.

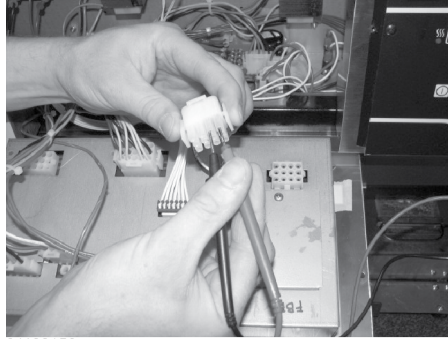

01180156

Figure 6-24 Temperature Probe Connector Check

6.8.2 Replacement

- 1) Pull-out on the drain valve knob and drain the oil from the vat.
- 2) Remove the rear panel (9 screws). See [Figure 6-25 Removing Rear Panel Screws](#), page 54.

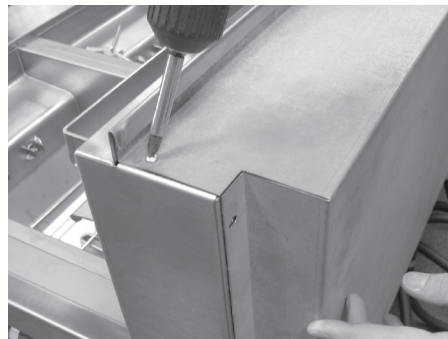

01180157

Figure 6-25 Removing Rear Panel Screws

- 3) Using a 1/2" wrench, remove the nut on the compression fitting, and remove the temperature probe from the vat. See [Figure 6-26 Removing Compression Fitting Nut](#), page 55.

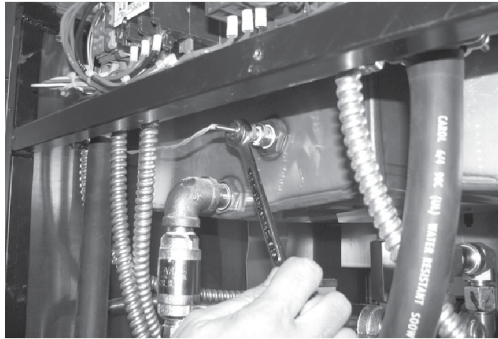

Figure 6-26 Removing Compression Fitting Nut

- 4) Follow the probe wires and disconnect the 2 probe connectors. (These may be found behind the control panel or behind the side panels, depending upon which vat is being serviced.) See [Figure 6-27 Temperature Probe Connectors](#), page 55.

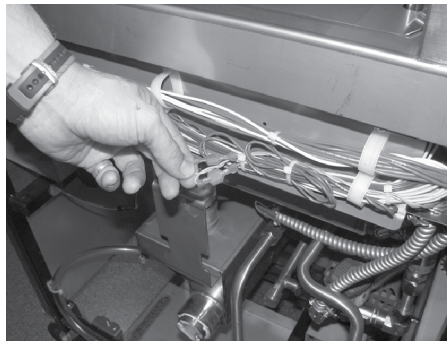

Figure 6-27 Temperature Probe Connectors

- 5) Locate temperature probe through pot wall.



CAUTION Excess force will damage temperature probe. Hand-tighten nut and then 1/2 turn with a wrench.

- 6) Place gauge against pot wall as shows in [Figure 6-28 Probe Assembly Install](#), page 56.

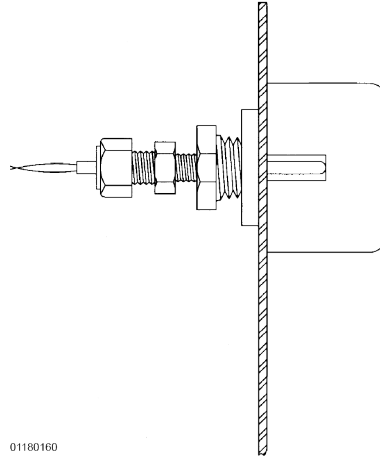

Figure 6-28 Probe Assembly Install

- 7) Push temperature probe through until it makes contact with gauge.
- 8) Tighten temperature probe in place.
- 9) Connect new temperature probe to the 2 fryer connections.
- 10) Replace rear cover and reconnect power to vat.
- 11) Lower element back into vat and close drain. Fill vat by pressing and holding the filter button until *FILTER* *MENU* shows in the display. Then once "1. EXPRESS FILTER" shows in the display, press the right arrow button 4 times until "5.FILL FROM PAN" shows in the display. Press ✓ button and "PUMP" "EXIT" shows in the display. Press ✓ button again, and oil fills vat. Once vat is full, press X twice to return to normal operation.

6.9 Oil Channel Clean-Out

Should the drain channel, under the vats, become clogged, access to a clean-out plug is available by removing the right or left side panels. See [Figure 6-29 Oil Channel Clean-Out Plug](#), page 57.

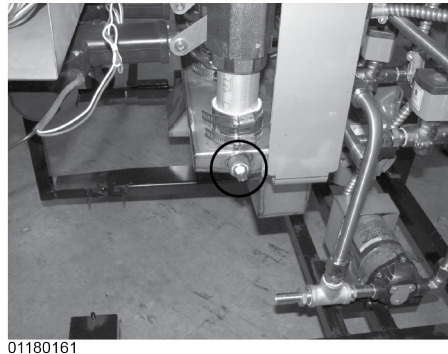

Figure 6-29 Oil Channel Clean-Out Plug

6.10 Element Safety Switch

This switch cuts power to the element when the element is raised. If a constant “E-31” “HEATING ELEMENTS ARE UP”, is shown on the display, when the elements are lowered into the vat, check the element safety switch.



WARNING To avoid electrical shock or property damage, move the power switch to OFF and disconnect main circuit breaker, or unplug cord at wall receptacle.

6.10.1 Checkout

- 1) Remove control panel and hinge it down.
- 2) Referring to the decal on the rear of the control panel, locate P9 connector (left vat-split vat) or P10 connector (full or right vat).
- 3) Pull the connector from the panel and using a multimeter, check for continuity between the 2 appropriate pins (labeled HEAT SWITCH). With the plunger on the safety switch pushed in (element lowered), the circuit should be closed. With the element raised, the circuit should be open. If the switch proves to be faulty, continue with replacement instructions. See [Figure 6-30 Element Safety Switch Connector Checkout](#), page 58.

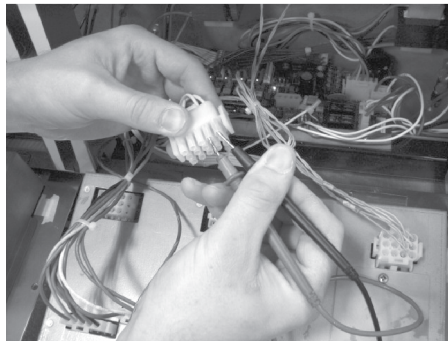

Figure 6-30 Element Safety Switch Connector Checkout

6.10.2 Replacement

- 1) Remove the rear panel (9 screws). See [Figure 6-31 Removing Rear Panel Screws](#), page 58.

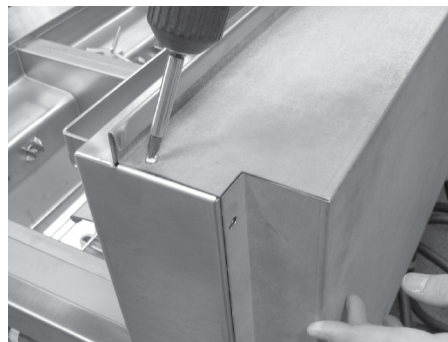
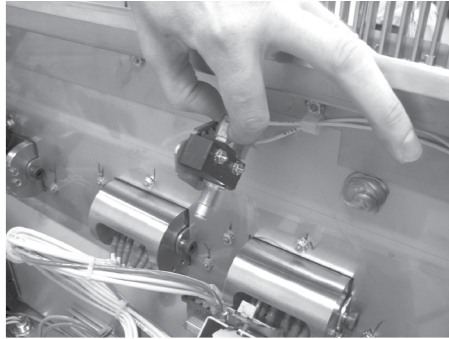

Figure 6-31 Removing Rear Panel Screws

- 2) Pull the wires from the switch. See [Figure 6-32 Removing Element Safety Switch Wires](#), page 59.



01180163

Figure 6-32 Removing Element Safety Switch Wires

- 3) Use crosshead screwdriver and remove the 2 screws securing the switch. See [Figure 6-33 Removing Element Switch Screws, page 59](#).

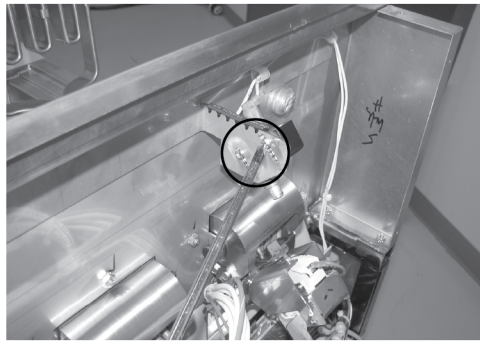

01180164

Figure 6-33 Removing Element Switch Screws

- 4) Reassemble with new switch, making sure the plate pushes-in the switch plunger, activating the switch, and then reconnect power to the fryer.

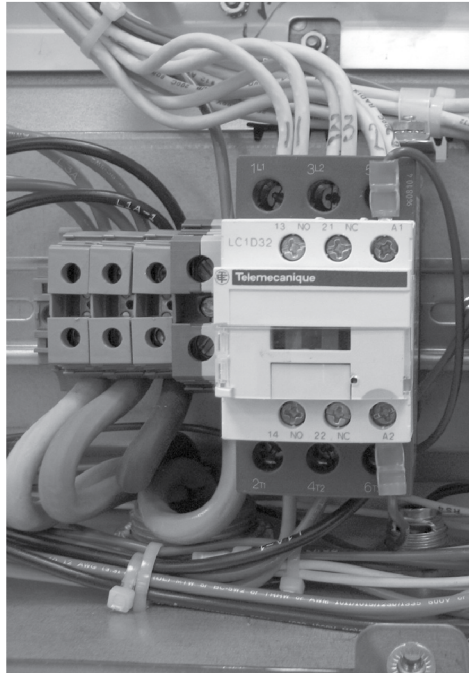

01180165

Figure 6-35 Heat Contactor

6.11.1 Checkout

- 1) Remove electrical power supplied to the fryer.



WARNING To avoid electrical shock or property damage, move the power switch to OFF and disconnect main circuit breaker, or unplug cord at wall receptacle.

- 2) Remove the top, rear panel.
- 3) Label and remove wires from contactors and perform a check on both contactors. See [Figure 6-36 Contactor Test Points](#), page 62.

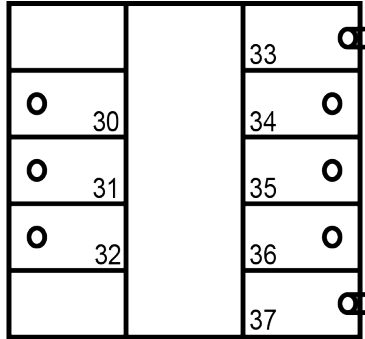

08170002

Figure 6-36 Contactor Test Points

Test Points	Results
From 30 to 34	open circuit
From 31 to 35	open circuit
From 32 to 36	open circuit
From 33 to 37 (coil)	ohm reading 5 to 6



WARNING SHOCK HAZARD

To avoid electrical shock, make connections before applying power, take reading, and remove power before removing meter leads. The following checks are performed with the wall circuit breaker closed and the main power switch in the on position.

- 4) With power reapplied and in a heat-up mode, check the power going to both contactor coils. Power should be going to both contactors. See [Figure 6-37 Heat Contactor Checkout](#), page 63.

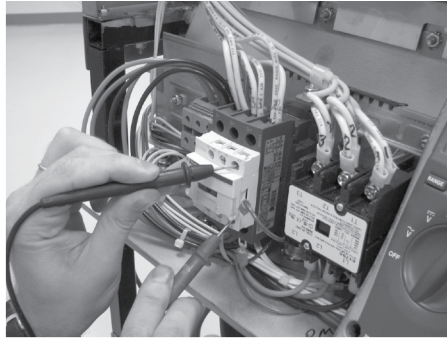

Figure 6-37 Heat Contactor Checkout

- 5) If no voltage is found going into the primary contactor coil, check wiring, high limit, and element switch.
- 6) If no voltage at heat contactor coil check wiring and connections at PC board.

6.11.2 Replacement

If either contactor proves defective, replace as follows:

! WARNING To avoid electrical shock or property damage, move the power switch to OFF and disconnect main circuit breaker, or unplug cord at wall receptacle.

- 1) Label and remove only those wires directly connected to the contactor being replaced. See [Figure 6-38 Removing Primary Contactor Wires](#), page 63.

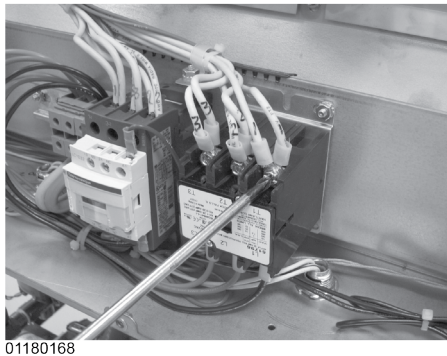
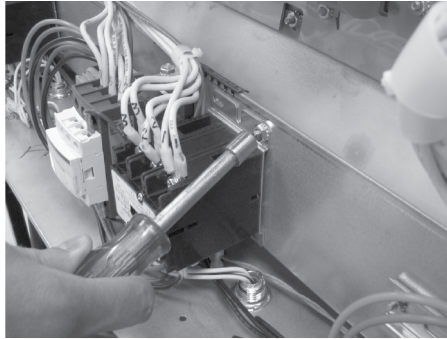

Figure 6-38 Removing Primary Contactor Wires

- 2) Using a 3/8" wrench or socket, remove the 2 mounting nuts on the base plate of the contactor being replaced and remove contactor. See [Figure 6-39 Removing Primary Contactor Nuts](#), page 64.



01180169

Figure 6-39 Removing Primary Contactor Nuts

- 3) When replacing the heat contactor, slide it from the mounting rail. See [Figure 6-40 Sliding Heat Contactor Off Mounting Rail, page 64](#).

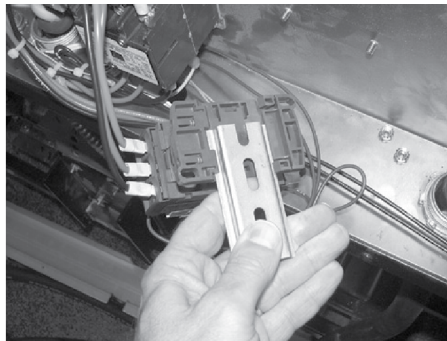

01180170

Figure 6-40 Sliding Heat Contactor Off Mounting Rail

- 4) Install new contactor in reverse order.
- 5) Replace rear panel and reconnect power to the fryer and test for proper operation.

6.12 Solenoid Valves

Each vat has a solenoid plumbed-into the oil return lines. They are normally closed, but open when power is supplied, such as, the controls are filling the vats.

! WARNING To avoid electrical shock or property damage, move the power switch to OFF and disconnect main circuit breaker, or unplug cord at wall receptacle.

- 1) Remove control panel and hinge it down.
- 2) Referring to the decal on the rear of the control panel, locate P3 connector (left vat-split vat) or P4 connector (full or right vat).
- 3) Pull the connector from the panel and using a multimeter, take an ohm reading on the appropriate pins. If ohm reading is significantly different than the chart below, continue with replacement instructions. See [Figure 6-41 Solenoid Valve Connector Checkout](#), page 65.

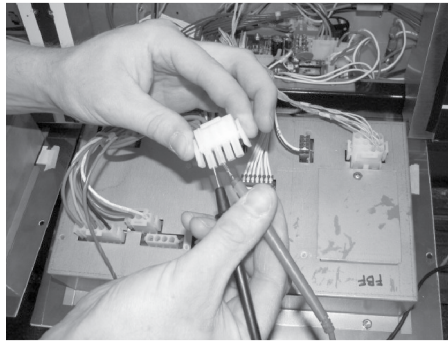

01180171

Figure 6-41 Solenoid Valve Connector Checkout

120 Volts - 60 Hertz	50 Ohms
220-240 Volts - 50 Hertz	230 Ohms

6.12.1 Replacement

- 1) Remove the rear panel (9 screws).
- 2) Remove the plastic retaining clip on top of the coil housing. See [Figure 6-42 Removing Retaining Clip, page 66](#).

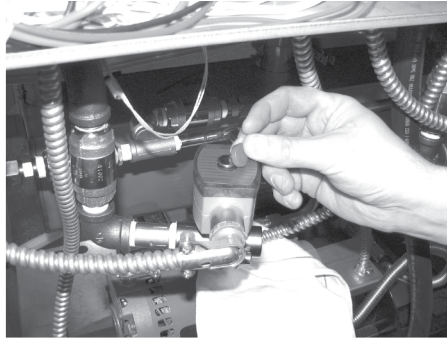

01180172

Figure 6-42 Removing Retaining Clip

- 3) Push-down and then lift-up on name-plate and remove the nameplate, cover and coil housing from solenoid stem. See [Figure 6-43 Removing Solenoid Nameplate, page 66](#).

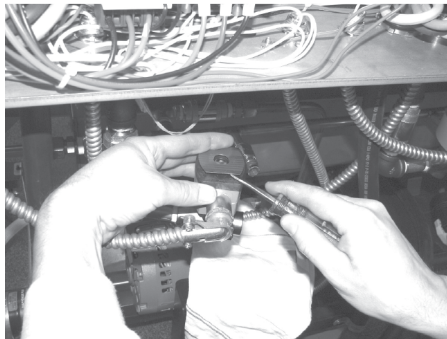

01180173

Figure 6-43 Removing Solenoid Nameplate

- 4) Using a 1 inch wrench, loosen the fitting on the right side of the solenoid. See [Figure 6-44 Loosening Right Solenoid Fitting, page 67](#).

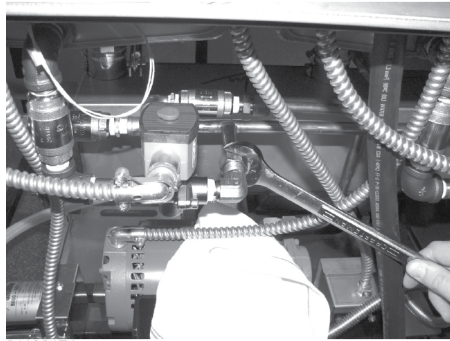

Figure 6-44 Loosening Right Solenoid Fitting

- 5) Pull the elbow away from the 1 inch nut, and using a 1-1/16 inch wrench or adjustable wrench, hold the solenoid in place while using another wrench to remove the elbow from the solenoid. Attach elbow to new solenoid, using pipe sealant on the threads. See [Figure 6-45 Removing Solenoid Elbow, page 67](#).

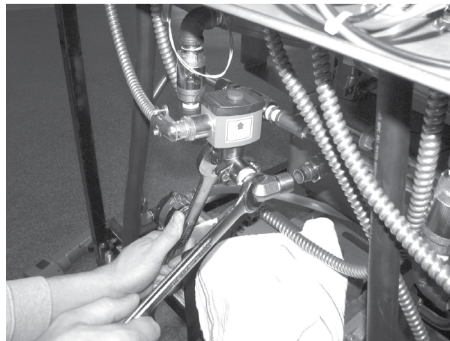
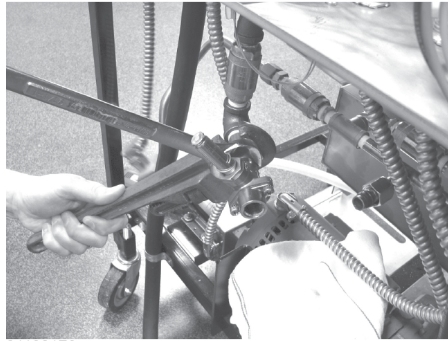

Figure 6-45 Removing Solenoid Elbow

- 6) Pull the coil housing from the solenoid stem. Hold the pipe nipple in place with a pipe wrench and using a 1-1/16" wrench or adjustable wrench, remove the solenoid from the nipple. See [Figure 6-46 Removing Solenoid Body, page 68](#).



01180176

Figure 6-46 Removing Solenoid Body

- 7) Remove the conduit from the fryer and pull the coil assembly from the fryer. See [Figure 6-47 Removing Conduit Nut, page 68](#).

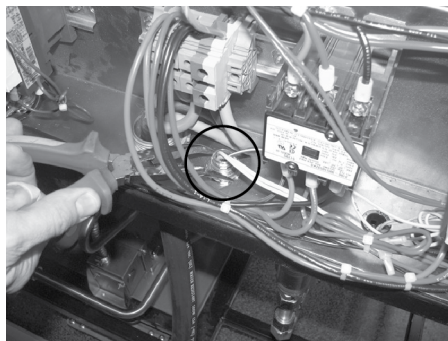

01180177

Figure 6-47 Removing Conduit Nut

- 8) Disconnect conduit at coil. See [Figure 6-48 Removing Conduit, page 69](#).

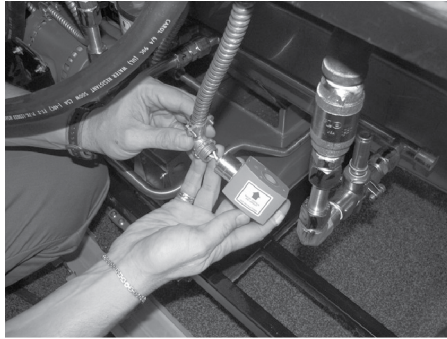

01180178

Figure 6-48 Removing Conduit

- 9) Thread the wires of the new solenoid through the conduit and reattach the conduit to the fryer.
- 10) Wire nut the solenoid wires onto the fryer wires, and then, attach the solenoid assembly onto the fittings of the fryer.
- 11) Replace rear cover and reconnect power to the fryer.

6.13 Filter Pump & Motor for Units Manufactured Prior to September 2018

The two most common causes for a fryer not to pump oil are that the pump is clogged, or the thermal overload switch has been tripped on the motor. The pump and motor assembly is located on the rear of the fryer.

6.13.1 Removing Debris from Pump

- 1) Loosen the four Allen head screws on the end of pump and remove the cover. (Removing the bottom rear panel may help in accessing the set screws.) See [Figure 6-49 Loosening Pump Cover Allen Screws](#), page 69.

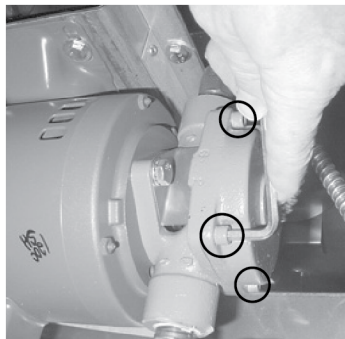

01180179

Figure 6-49 Loosening Pump Cover Allen Screws

- 2) The inside is now exposed leaving a rotor and five Teflon rollers. Clean the rotor and rollers. See [Figure 6-50 Filter Pump Exposed](#), page 70.

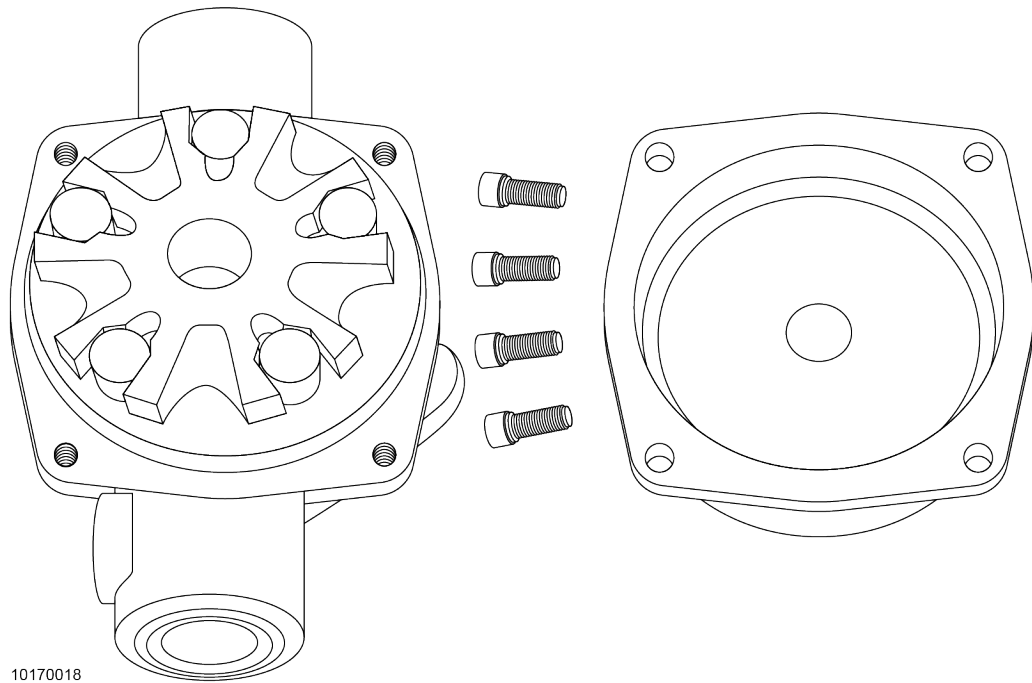

Figure 6-50 Filter Pump Exposed

- 3) To reassemble, place rotor on drive shaft, and place roller into rotor.



CAUTION

There is an indicator on the side of the two halves of the pump, this mark must be together. See [Figure 6-51 Aligning Filter Pump Mark](#), page 70.

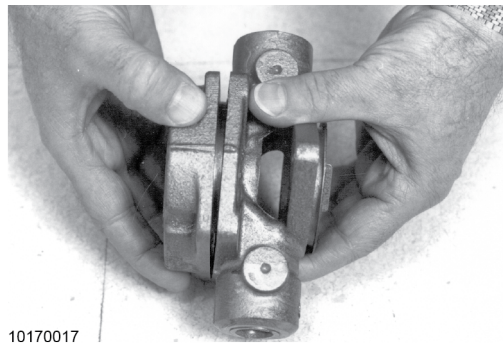

Figure 6-51 Aligning Filter Pump Mark

NOTE: A small amount of grease might be needed to hold the bottom roller into place until cover plate is put on. Make sure O-ring is in proper position on plate.

6.13.2 Resetting Thermal Overload Switch

- 1) Locate the pump and motor in the rear of the fryer and if the motor is hot, allow it to cool for about 5 minutes.
- 2) Since it takes some effort to reset the switch, use a tool, such as a crosshead screwdriver, to press against the reset button until a “click” is heard. See [Figure 6-52 Resetting Thermal Overload Switch, page 71](#).

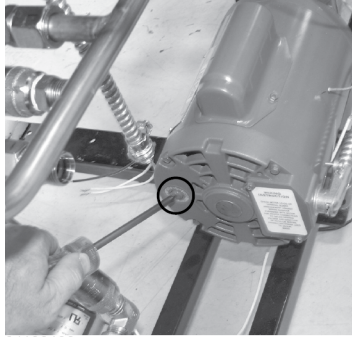

Figure 6-52 Resetting Thermal Overload Switch

6.13.3 Motor Removal

⚠ WARNING To avoid electrical shock or property damage, move the power switch to OFF and disconnect main circuit breaker, or unplug cord at wall receptacle.

- 1) Remove JIB from fryer.
- 2) Remove the rear panel and the right side panel.
- 3) Using a 7/8” wrench, loosen the front flexible line fitting on the pump. See [Figure 6-53 Loosening Front Flexible Line Fitting, page 72](#).

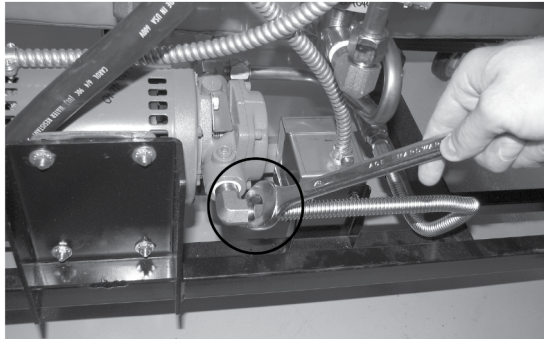

Figure 6-53 Loosening Front Flexible Line Fitting

- 4) Using a 1" wrench, loosen the rear pump fitting. See [Figure 6-54 Loosening Rear Pump Fitting, page 72](#).

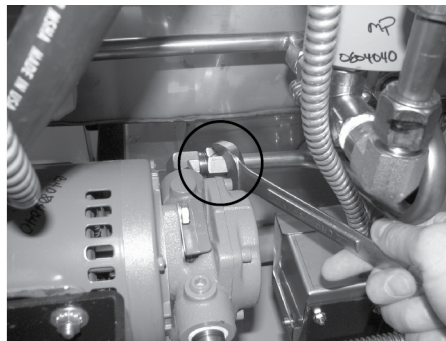
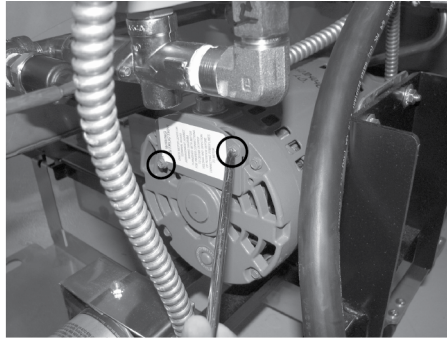

Figure 6-54 Loosening Rear Pump Fitting

- 5) Using crosshead screwdriver, remove the rear cover from motor, exposing the wires. See [Figure 6-55 Removing Rear Motor Cover, page 73](#).



01180183

Figure 6-55 Removing Rear Motor Cover

- 6) Loosen the conduit clamp and pull the wires through the conduit clamp.
- 7) Using a $7/16$ in. wrench, remove the 4 bolts securing the motor to the motor bracket and pull the pump and motor assembly from fryer. See [Figure 6-56 Removing Motor Bracket Bolts](#), page 73.

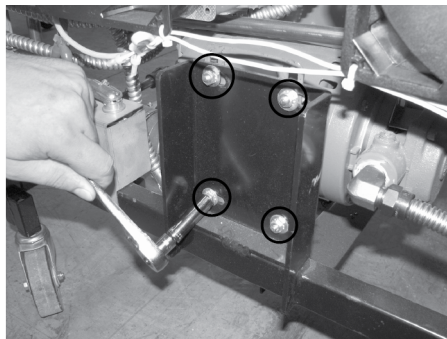

01180184

Figure 6-56 Removing Motor Bracket Bolts

- 8) Pull pump and motor out from front of fryer across the JIB shelf.

6.13.4 Replacement Of Pump Motor

- 1) Using a $1/2$ in. wrench, remove the 2 bolts securing the pump to the motor and pull the pump from the motor.
- 2) Install a new seal kit (part no. 17476) onto shaft of motor.
- 3) Align the shaft of the motor with the rotor on the inside of the pump and push pump onto shaft of motor.
- 4) Secure the pump onto the motor with the 2 bolts.

6.14 HubMounted Filter Pump and Motor Assembly

Included on units manufactured after September 2018.

6.14.1 Removing Debris from Pump

- 1) Loosen the four Allen head screws on the end of pump and remove the cover. (Removing the bottom rear panel may help in accessing the set screws.)

Figure 6-57 Loosening Pump Cover Allen Screws

- 2) The inside is now exposed leaving a rotor and five Teflon rollers. See [Figure 6-50 Filter Pump Exposed, page 70](#).

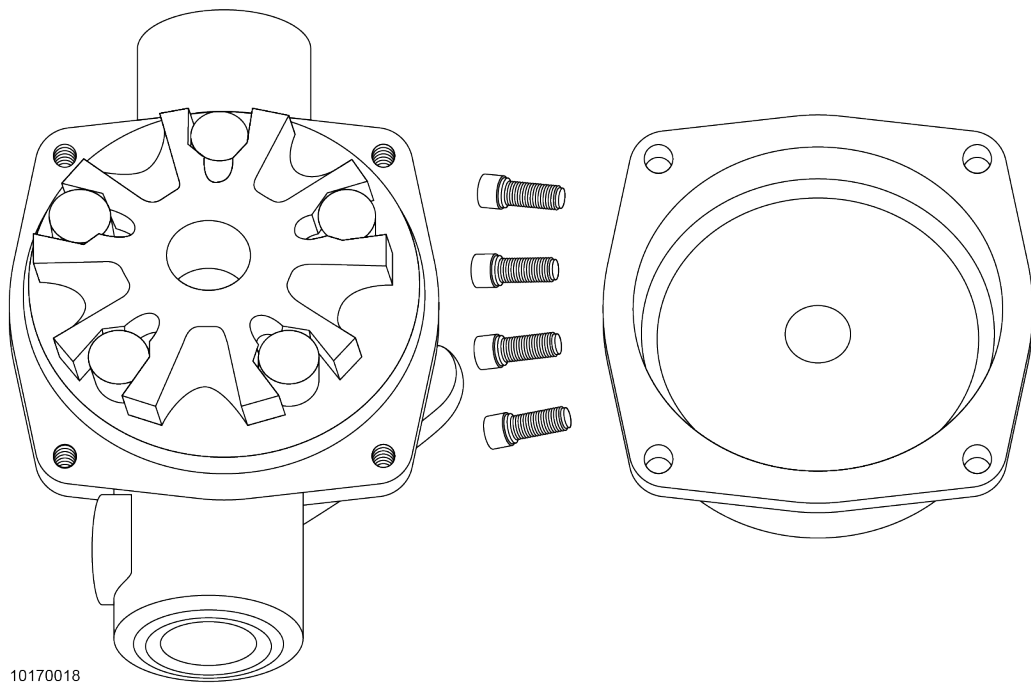

Figure 6-58 Filter Pump Exposed



CAUTION

Removing rotor will break filter pump body internal seal. To prevent product damage, **DO NOT** remove rotor from pump body.

- 3) Remove the rollers and clean.
- 4) Without removing the rotor, wipe it clean.
- 5) Place rollers back on rotor.

NOTE: A small amount of grease might be needed to hold the bottom roller into place until cover plate is put on. Make sure O-ring is in proper position on plate.

6) Align filter pump cover and secure with 4 screws.

6.14.2 Replacing the Hubmounted Filter Pump

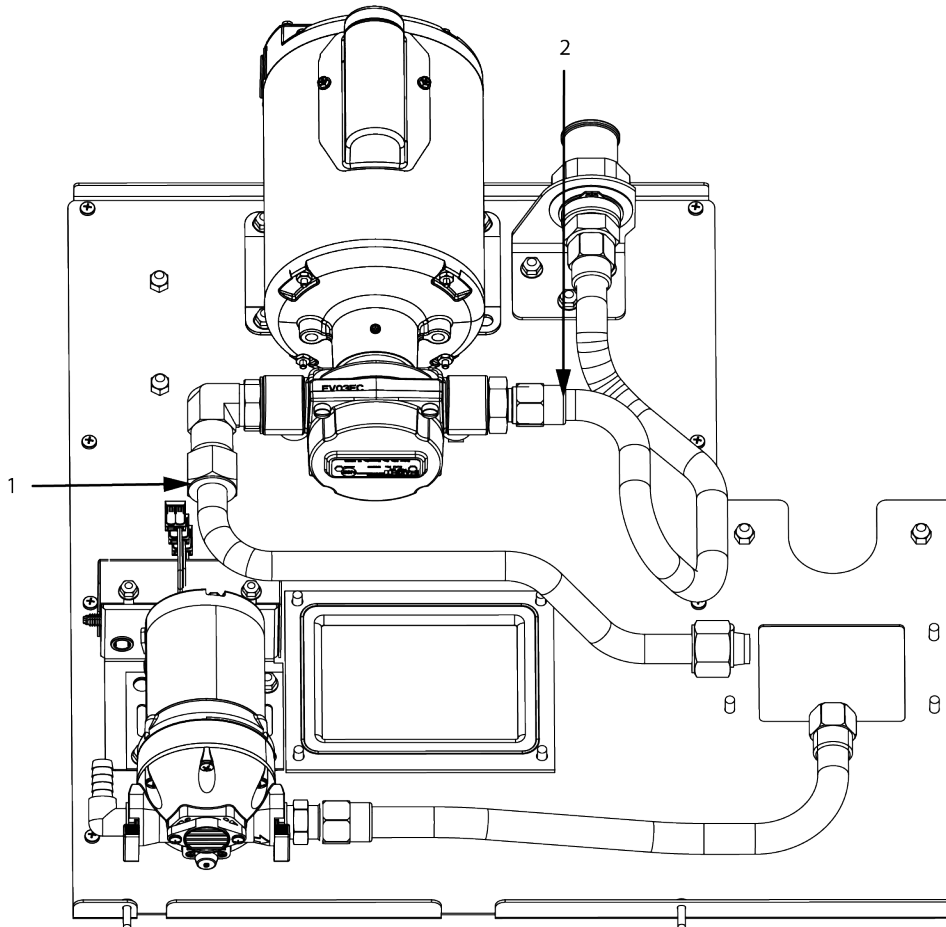

Figure 6-59 SAE Fittings on Hubmounted Filter Pump and Motor

- 1) Remove the rear panel and the right side panel.
- 2) Using a 7/8" wrench, disconnect the outlet tube flexible line fitting (1) on the pump.
- 3) Using a 1" wrench, disconnect the suction tube pump fitting (2) .

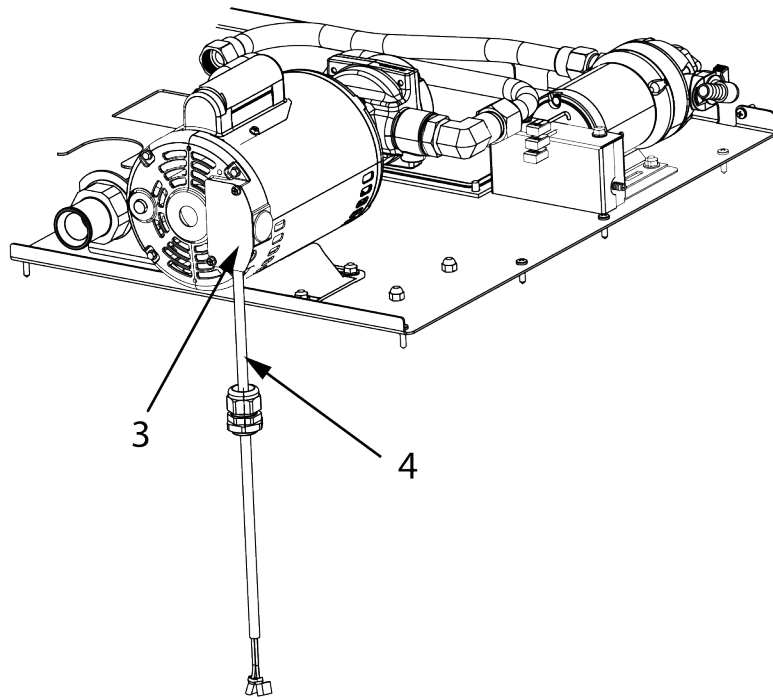

Figure 6-60 Motor Access Plate

- 4) Using a crosshead screw driver, remove access plate (3) from motor.
- 5) Disconnect the conduit wires (4) from the pump.

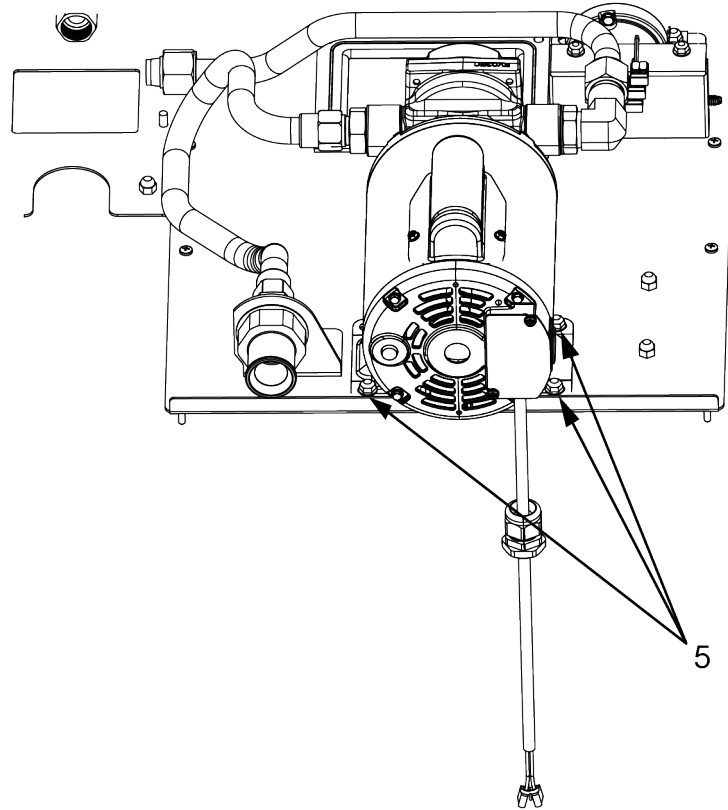

Figure 6-61 Motor Mounting Plate

- 6) Using a 7/16 in. wrench, remove the 4 bolts (5) securing the motor to the mounting plate and remove the pump and motor assembly from fryer.
- NOTE: Some units may only have 3 bolts securing the motor to the mounting plate.
- 7) Align the new filter pump and motor assembly to the holes on the mounting plate and install with 4 bolts. See [Figure 6-61 Motor Mounting Plate, page 77](#).
 - 8) Reconnect the conduit wires to the pump.
 - 9) Using a crosshead screw driver, install access plate on motor. See .
 - 10) Attach the new straight SAE fitting to the motor. See [Figure 6-59 SAE Fittings on Hubmounted Filter Pump and Motor, page 75](#).
 - 11) Attach the new elbow SAE fitting to the motor.
 - 12) Attach the straight fitting to the suction tube.
 - 13) Attach the elbow fitting to the outlet tube.

6.14.3 Replacing the Motor Assembly

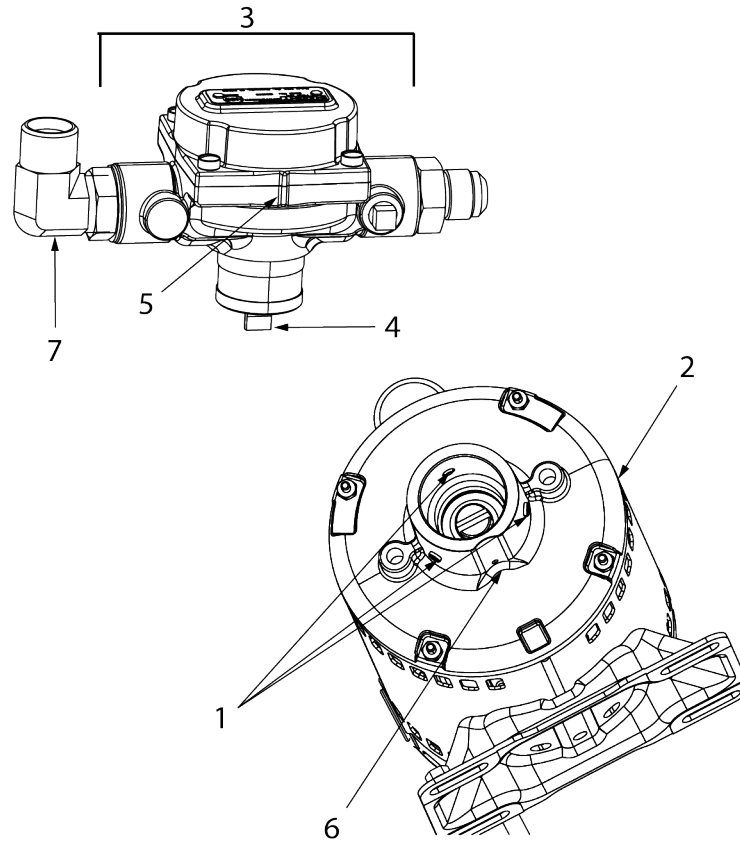

Figure 6-62 Replacing the Motor Assembly

- 1) Remove the 3 screws (1) securing the pump to the motor and pull the pump (2) from the motor (3).
- 2) Align the shaft of the motor (4) with the pump ensuring that the groove on the motor (5) aligns with the groove on the pump (6).

NOTE: This should be the 3 o'clock position. The inlet port with the attached elbow SAE fitting (7) should be on the side closest to the JIB pump.

- 3) Press pump onto shaft of motor.
- 4) Secure the pump onto the motor with the 3 screws.

6.15 JIB Pump

This pump keeps the vats filled and is used in the Oil Guardian™ process.

6.15.1 Replacement

! WARNING To avoid electrical shock or property damage, move the power switch to OFF and disconnect main circuit breaker, or unplug cord at wall receptacle.

- 1) Remove the right side panel.
- 2) Using a 1 inch wrench, loosen fitting on right side of pump. See [Figure 6-63 Loosening Right Pump Fitting, page 79](#).

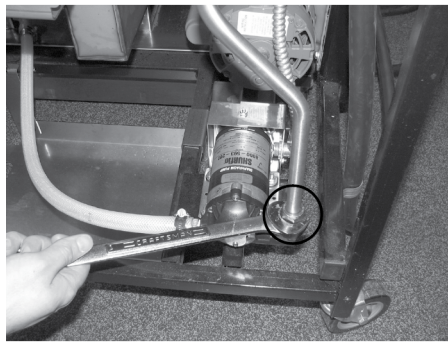

01180185

Figure 6-63 Loosening Right Pump Fitting

- 3) Remove the hose from the pump. See [Figure 6-64 Removing Hose Clamp, page 79](#).

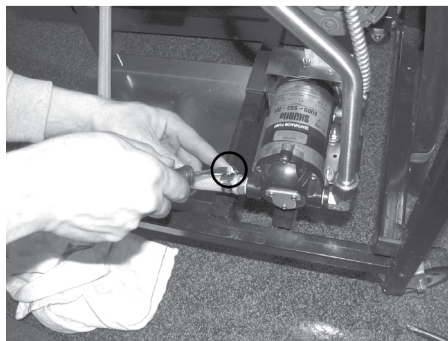

01180186

Figure 6-64 Removing Hose Clamp

- 4) Remove the 4 bolts securing the bottom of pump. See [Figure 6-65 Removing Pump Mounting Bolts, page 80](#).

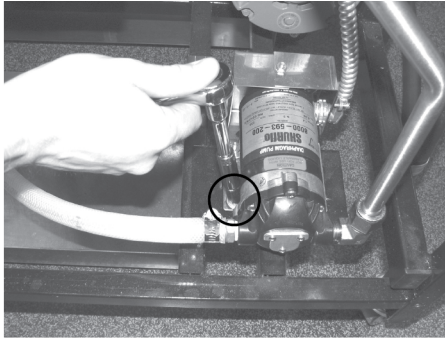

Figure 6-65 Removing Pump Mounting Bolts

- 5) Disconnect the wires in the rear of the pump and pull assembly from fryer.
- 6) Pull fittings from faulty pump and attach the fittings to the new pump in the same orientation.
- 7) Install new pump assembly in fryer, in reverse order and then reconnect power to fryer.

6.16 Express Filter PC Board

This electronic board controls the Automatic Intermittent Filtering process.

6.16.1 Replacement

⚠ WARNING To avoid electrical shock or property damage, move the power switch to OFF and disconnect main circuit breaker, or unplug cord at wall receptacle.

- 1) Hinge-down the center control panel (right panel on 2 vat units).
- 2) Pull connectors from PC board, located behind control panel. See [Figure 6-66 Removing PC Board Connectors, page 81](#).

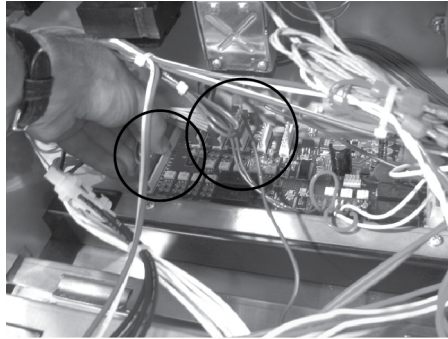

01180188

Figure 6-66 Removing PC Board Connectors

- 3) Using a 5/16" socket, remove the 6 nuts securing the board and remove it from the fryer. See [Figure 6-67 PC Board Nuts, page 81](#).

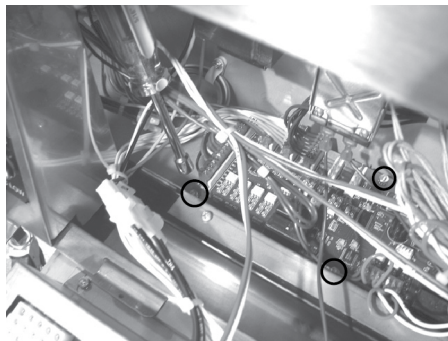

01180189

Figure 6-67 PC Board Nuts

- 4) Install in reverse order. The control connectors are colored-coded; Left-Red; Middle-White; Right-Blue.

6.17 Transformers

Both the Express Filter transformer and the control transformer are the same part number. These components drop the line voltage to low voltage components such as, control board, Express Filter board and contactors.

6.17.1 Checkout



WARNING To avoid electrical shock or property damage, move the power switch to OFF and disconnect main circuit breaker, or unplug cord at wall receptacle.

- 1) Hinge-down the control panel to access the desired transformer.
- 2) Pull the appropriate white connector, either from the Express Filter PC board or from the control PC board. See [Figure 6-68 Pulling Transformer Connector](#), page 82.

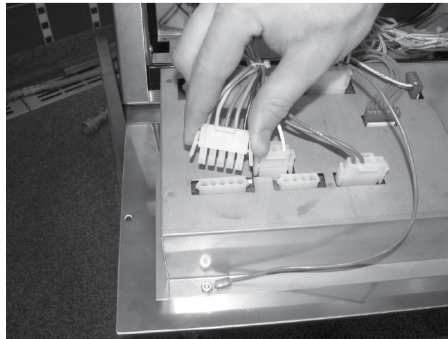

01180190

Figure 6-68 Pulling Transformer Connector



WARNING To avoid electrical shock or property damage, move the power switch to OFF and disconnect main circuit breaker, or unplug cord at wall receptacle.

- 3) With the power on, take a voltage reading on the appropriate pins, using the chart and drawing below. If transformer proves faulty, continue with replacement instructions. See [Figure 6-69 Transformer Connector Checkout](#), page 83.

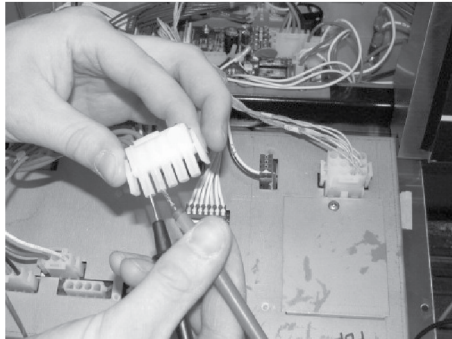

01180191

Figure 6-69 Transformer Connector Checkout

Test Points	Results
From pin 1 to 2	24 VAC
From pin 4 to 5	240 VAC
From pin 3 to 5	208 VAC

6.17.2 Replacement

- 1) Disconnect power and using a 5/16" socket, remove the nuts securing the transformer and pull the transformer from unit. See [Figure 6-70 Removing Express Filter Transformer Nuts](#), page 83 and [Figure 6-71 Removing Control Transformer Nuts](#), page 84.

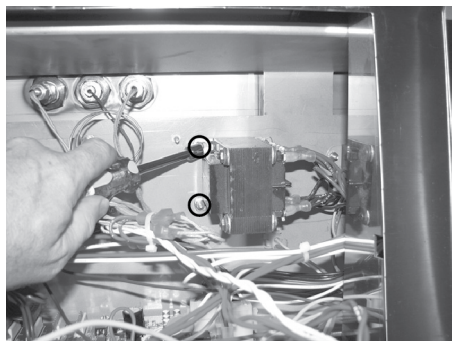

01180192

Figure 6-70 Removing Express Filter Transformer Nuts

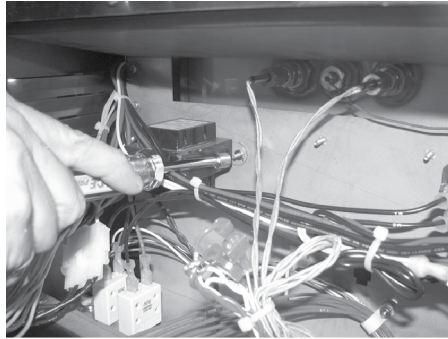

01180274

Figure 6-71 Removing Control Transformer Nuts

- 2) Replace transformer in reverse order.

6.18 Installing Arby's SiteSage Radio

This component is located behind the left control panel.

6.18.1 Installing SiteSage Radio Hardware

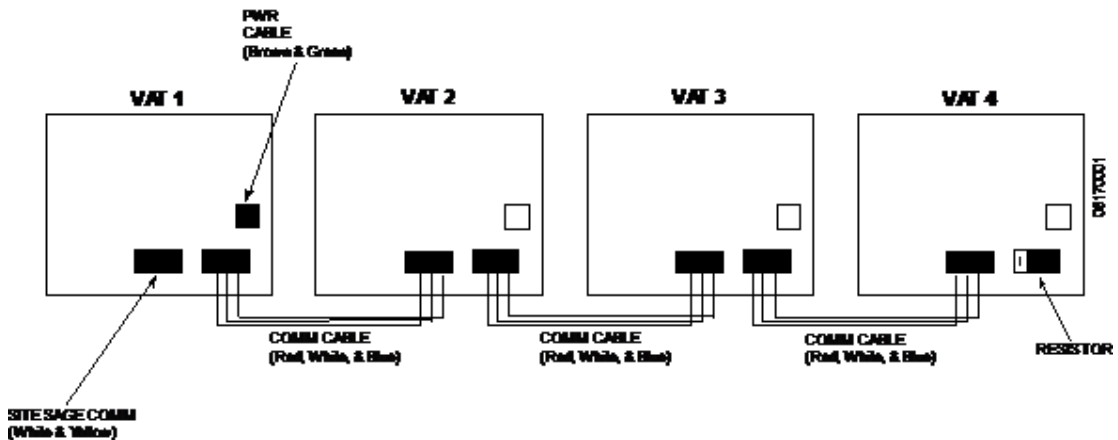
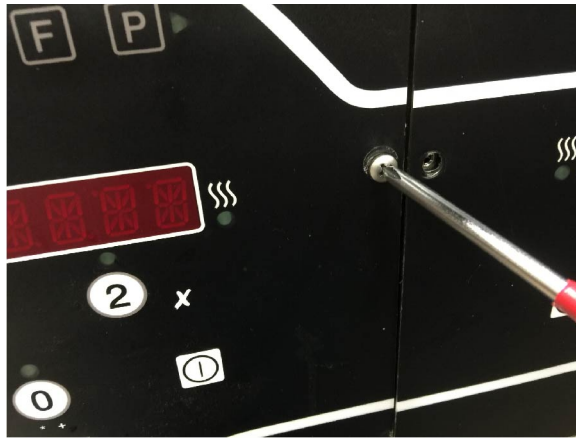

Figure 6-72 SiteSage Wiring



WARNING To avoid electrical shock or property damage, move the power switch to OFF and disconnect main circuit breaker, or unplug cord at wall receptacle.

- 1) Remove two screws from control panel on first left well and tilt down.



- 2) Center the control panel radio assembly against component shroud in first left well.
- 3) Mark location for holes.
- 4) Drill .140 diameter holes in the locations you marked.
- 5) Mount radio assembly onto component shroud with two screws.

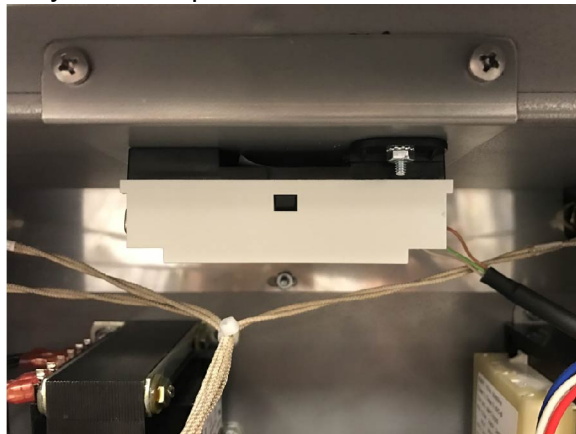

- 6) Remove existing control panel access covers and discard.



- 7) Insert radio harness connector into each control.

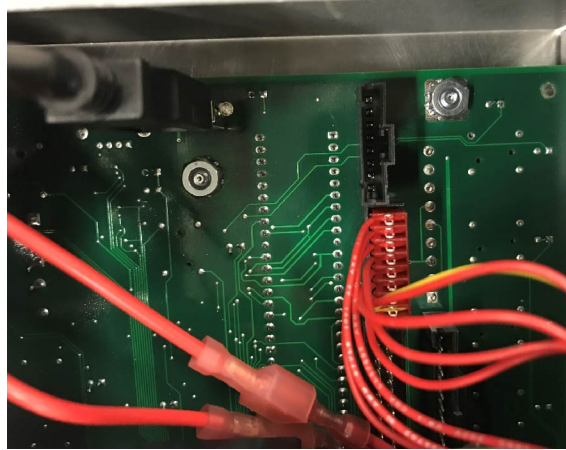

- 8) Install new control access covers onto controls using existing hardware.
- 9) Insert SiteSage radio wires in terminals.
- 10) Insert control communication wires into control and run harnesses to all controls except last.

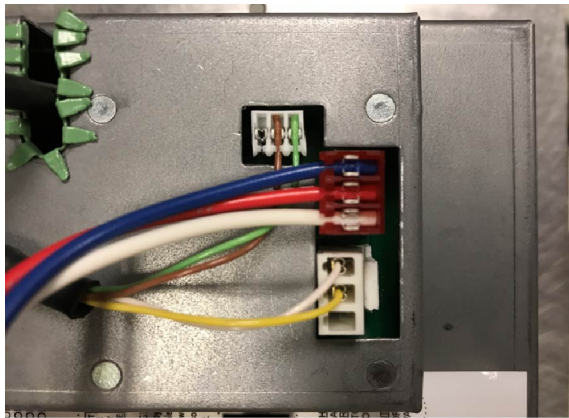

- 11) On last control, insert control communication wire into control and attach resistor to other end of harness.
- 12) Run harness with resistor to control.
- 13) Lift all but first left control panel and secure with two screws per panel.
- 14) Move the power switch to ON.
- 15) Ensure the LED light illuminates and the radio functions properly.



16) Lift first left control panel and secure with two screws.

17) Follow procedure in [6.18.2 Enabling the Control MODBUS](#), page 87.

6.18.2 Enabling the Control MODBUS

- 1) Press and hold the P button until LEVEL 2 displays on the control.
- 2) Use the left/right arrow button to navigate to the DATA COMM menu.
- 3) Using the number pad, enter password 123.
- 4) Use left arrow button to navigate to DC-11 MODBUS ENABLED.
- 5) Use the up/down button to select YES.

6) Press and hold the P button to save selection and exit DATA COMM menu.

Control and radio are able to communicate after MODBUS is enabled. Connect the radio to the store network/gateway. The network/gateway can request information from the radio which acquires the requested information from the control and then returns the information to the network/gateway.

6.19 Filter Motor Relay

This component is located behind the left control panel and regulates voltage to the filter motor.



WARNING To avoid electrical shock or property damage, move the power switch to OFF and disconnect main circuit breaker, or unplug cord at wall receptacle.

- 1) Hinge-down the left control panel.
- 2) Label and remove wires from relay. See [Figure 6-73 Removing Relay Wires](#), page 88.

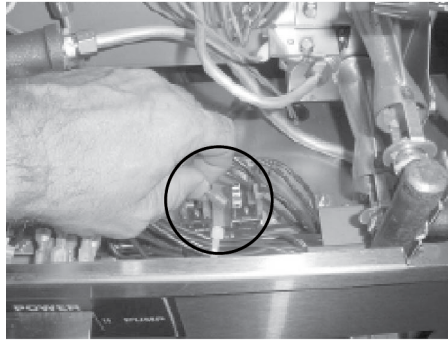

01180193

Figure 6-73 Removing Relay Wires

-
- 3) Using a 5/16 inch wrench, remove the nuts securing the relay and remove relay from fryer. See [Figure 6-74 Removing Relay Nuts, page 88](#).

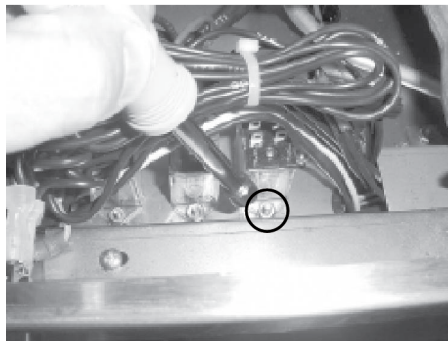

01180194

Figure 6-74 Removing Relay Nuts

- 4) Install new relay in reverse order.

6.20 Drain Pan Switch

This switch closes when the drain pan is pushed properly in place under the fryer. If the drain pan is not properly in place, or the drain switch is faulty, display prompts such as, “CHECK PAN”; “FILTER PAN MISSING”; “CHANGE FILTER PAD” shows in the display.

! WARNING To avoid electrical shock or property damage, move the power switch to OFF and disconnect main circuit breaker, or unplug cord at wall receptacle.

- 1) Remove control panel and hinge it down.
- 2) Locate the 8-pin connector on the Express Filter PC board and pull the connector from the board.
- 3) Check for normally open circuit between the pins with wires labeled D1 & D2. If the circuit shows closed, continue with the replacement instructions below.

6.20.1 Replacement

- 1) Drain pan switch is located on the rear of the fryer. Using a 3/8 inch socket or nut driver, remove the nuts securing the drain switch bracket to the fryer. See [Figure 6-75 Removing Drain Switch Bracket Nuts, page 89](#).

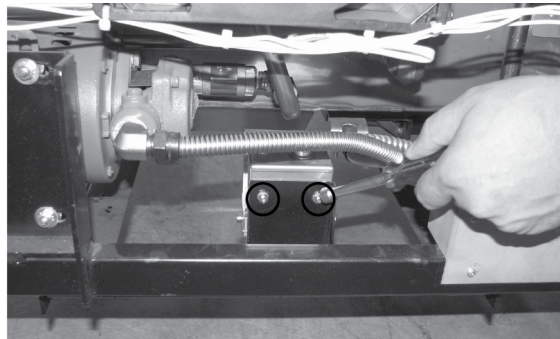
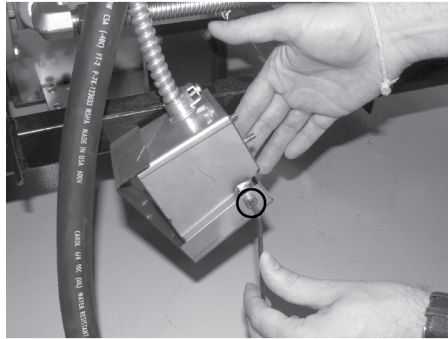

Figure 6-75 Removing Drain Switch Bracket Nuts

- 2) Using a 1/8” Allen wrench, remove the shoulder bolt securing the cover and remove cover. See [Figure 6-76 Removing Drain Switch Shoulder Bolt, page 90](#) and [Figure 6-77 Inside of Drain Switch Box, page 90](#).



01180196

Figure 6-76 Removing Drain Switch Shoulder Bolt

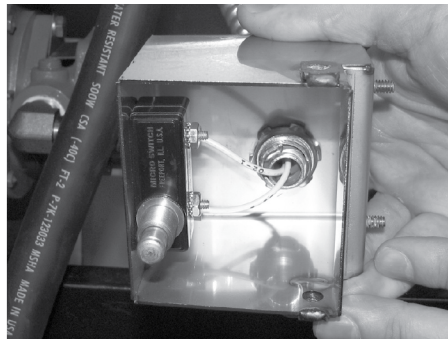

01180197

Figure 6-77 Inside of Drain Switch Box

- 3) Using a crosshead screwdriver, remove the screws securing the switch to the bracket and remove switch from the bracket. See [Figure 6-78 Removing Drain Switch Bracket Screws](#), page 90.

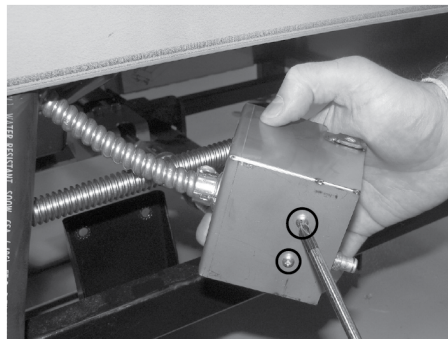

01180198

Figure 6-78 Removing Drain Switch Bracket Screws

- 4) Label and remove wires from switch.
- 5) Replace faulty switch, placing wires on new switch on the normally open(1) and common(2) terminals. See [Figure 6-79 Drain Pan Switch, page 91](#).

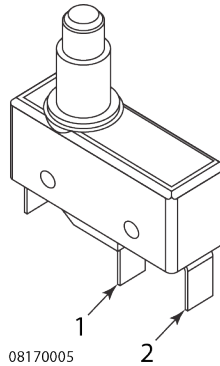

Figure 6-79 Drain Pan Switch

6.21 Filter Beacon®

6.21.1 Replacement

! WARNING To avoid electrical shock or property damage, move the power switch to OFF and disconnect main circuit breaker, or unplug cord at wall receptacle.

- 1) Remove right or left side panel for end vats, or hinge-down the control panel for center vats.
- 2) Pull apart the light by pulling on the rear of the light and removing the front part of the light from the front of the fryer. See [Figure 6-80 Filter Beacon Rear, page 91](#) and [Figure 6-81 Pulling Front of Filter Beacon, page 92](#).

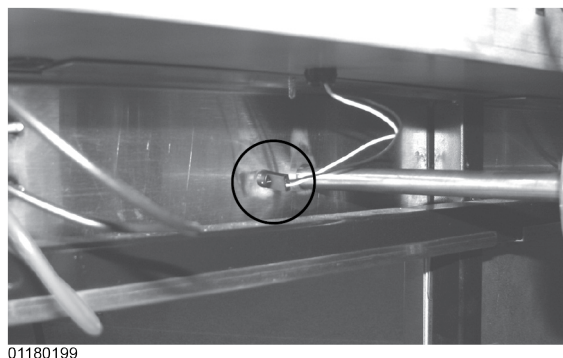

01180199

Figure 6-80 Filter Beacon Rear

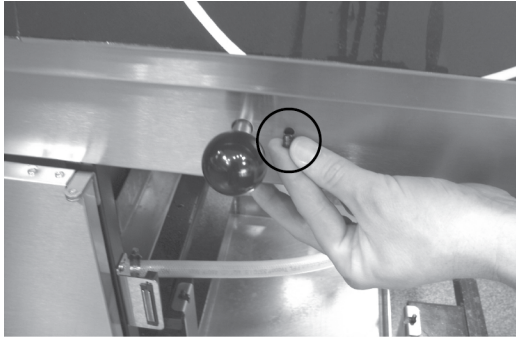

01180200

Figure 6-81 Pulling Front of Filter Beacon

- 3) Locate and cut the light wires and pull the light from unit. See [Figure 6-82 Filter Beacon Wires](#), page 92.

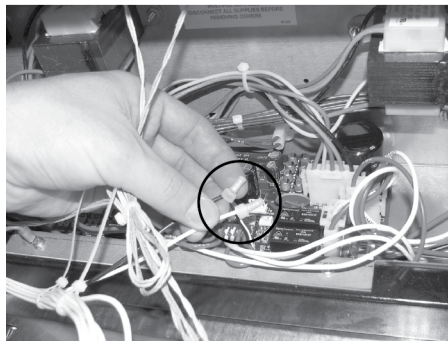

01180201

Figure 6-82 Filter Beacon Wires

- 4) Connect new light wires using wirenuts, and install light in reverse order.
- 5) Restore power to the unit.

6.22 Oil Level Probes

The oil level probes monitor the oil level by temperature differences. If they become disabled, the display shows: "E-18A"= left probe; "E18-B"= right probe; "E18C"= both. Also, if any of the probes are out of calibration more than 10°F, or 10°C, the temperature probe should be replaced. (See [5.5 Tech Mode](#), page 31 for probe calibration steps.) An Ohm check can be performed also. See chart below.

6.22.1 Checkout



WARNING To avoid electrical shock or property damage, move the power switch to OFF and disconnect main circuit breaker, or unplug cord at wall receptacle.

- 1) Remove control panel and hinge it down.
- 2) Referring to the decal on the rear of the control panel, locate the 12-pin probe connector in the upper, right-hand corner. (An ohm chart is also shown on the decal.)
- 3) Pull the connector from the panel and using a multimeter, take an ohm reading on the appropriate Level Probe pins. If ohm reading is significantly different than what is shown in [Table 6-3 RTD Resistance Chart, page 94](#), continue with replacement procedure.

Table 6-3 RTD Resistance Chart

°F	°C	Resistance Ohms	°F	°C	Resistance Ohms	°F	°C	Resistance Ohms
50	10.00	1039.02	190	87.78	1338.57	325	162.78	1620.77
60	15.56	1060.65	200	93.33	1359.69	330	165.56	1631.09
70	21.11	1082.24	210	98.89	1380.79	340	171.11	1651.72
80	26.67	1103.80	212	100.00	1385.00	350	176.67	1672.31
90	32.22	1125.32	220	104.44	1401.84	360	182.22	1692.86
100	37.78	1146.81	230	110.00	1422.86	365	185.00	1703.13
110	43.33	1168.26	240	115.56	1443.85	370	187.78	1713.38
120	48.89	1189.67	250	121.11	1464.79	380	193.33	1733.87
130	54.44	1211.05	260	126.67	1485.71	390	198.89	1754.31
140	60.00	1232.39	270	132.22	1506.58	400	204.44	1774.72
150	65.56	1253.70	280	137.78	1527.43	410	210.00	1795.10
160	71.11	1274.97	290	143.33	1548.23	420	215.56	1815.44
170	76.67	1296.20	300	148.89	1569.00	430	221.11	1835.74
180	82.22	1317.40	310	154.44	1589.73	440	226.67	1856.01
185	85.00	1327.99	320	160.00	1610.43			

6.22.2 Replacement

- 1) Pull-out on the drain knob and drain oil from vat.
- 2) Using a 1/2 inch wrench, remove the nut on the compression fitting, and remove the temperature probe from the vat. See [Figure 6-83 Removing Level Sensor Fitting](#), page 94.

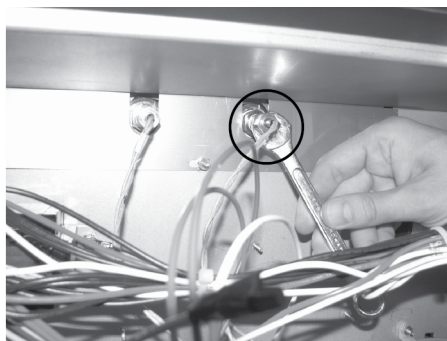

01180202

Figure 6-83 Removing Level Sensor Fitting

- 3) Using a terminal extractor, remove the probe terminals from the connector and remove probe from unit. See [Figure 6-84 Level Sensor Probe Checkout](#), page 95.



01180275

Figure 6-84 Level Sensor Probe Checkout

- 4) Place the nut and new ferrule on the new temperature probe and insert the temperature probe into the compression fitting.
- 5) Locate temperature probe through pot wall.
- 6) Place gauge against pot wall as shows in [Figure 6-28 Probe Assembly Install](#), page 56.

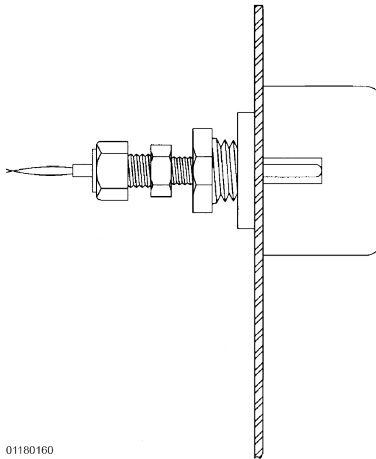

01180160

Figure 6-85 Probe Assembly Install

- 7) Push temperature probe through until it makes contact with gauge.
- 8) Tighten temperature probe in place.



CAUTION

Excess force will damage temperature probe. Hand-tighten nut and then 1/2 turn with a wrench.

- 9) Connect new temperature probe to the connector and fasten connector onto control panel.
- 10) Replace control panel and reconnect power to vat.
- 11) Fill vat by pressing and holding the filter button until *FILTER* *MENU* shows in the display. Then once "1.EXPRESS FILTER" shows in the display, press the right arrow button 4 times until "5.FILL FROM PAN" shows in the display. Press √ button and "PUMP" "EXIT" shows in the display. Press √ button again, and oil fills vat. Once vat is full, press X twice to return to normal operation.

6.23 Drain Rod Microswitch

This component prevents the elements from heating while the drain is open by disrupting the power to the heat contactor.

6.23.1 Checkout



WARNING To avoid electrical shock or property damage, move the power switch to OFF and disconnect main circuit breaker, or unplug cord at wall receptacle.

- 1) Remove control panel and hinge it down.
- 2) Referring to the decal on the rear of the control panel, locate P9 connector (left vat-split vat) or P10 connector (full or right vat).
- 3) Check for normally open circuit between the 2 appropriate pins. If the circuit shows closed, continue with the replacement instructions below.

6.23.2 Replacement

- 1) Remove right or left side panel, depending upon what side the faulty switch is on.
- 2) Pull connector from behind control panel area. See [Figure 6-86 Pulling Drain Microswitch Connector, page 97](#).

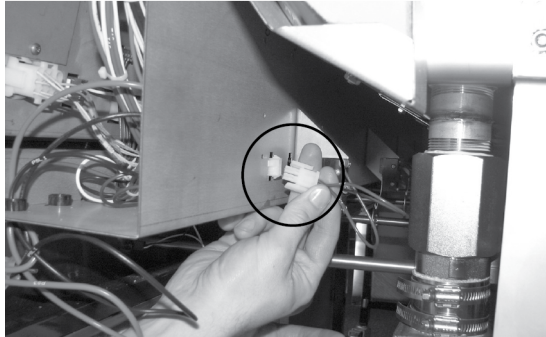

Figure 6-86 Pulling Drain Microswitch Connector

- 3) Using crosshead screwdriver and a 5/16" socket, remove the nut and screw securing the switch and remove switch from unit. See [Figure 6-87 Removing Drain Microswitch Screws, page 97](#).

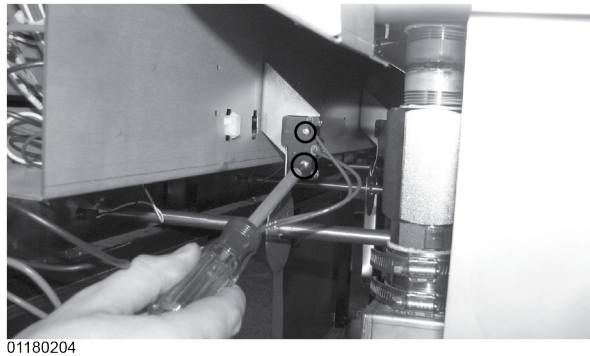

Figure 6-87 Removing Drain Microswitch Screws

- 4) Remove wires from switch and place on new switch, placing them on the normally open and common terminals.
- 5) Install new switch in reverse order.

Chapter 7 Wiring Diagrams

The wiring diagrams are shown in this section.

7.1 208/240 Volt

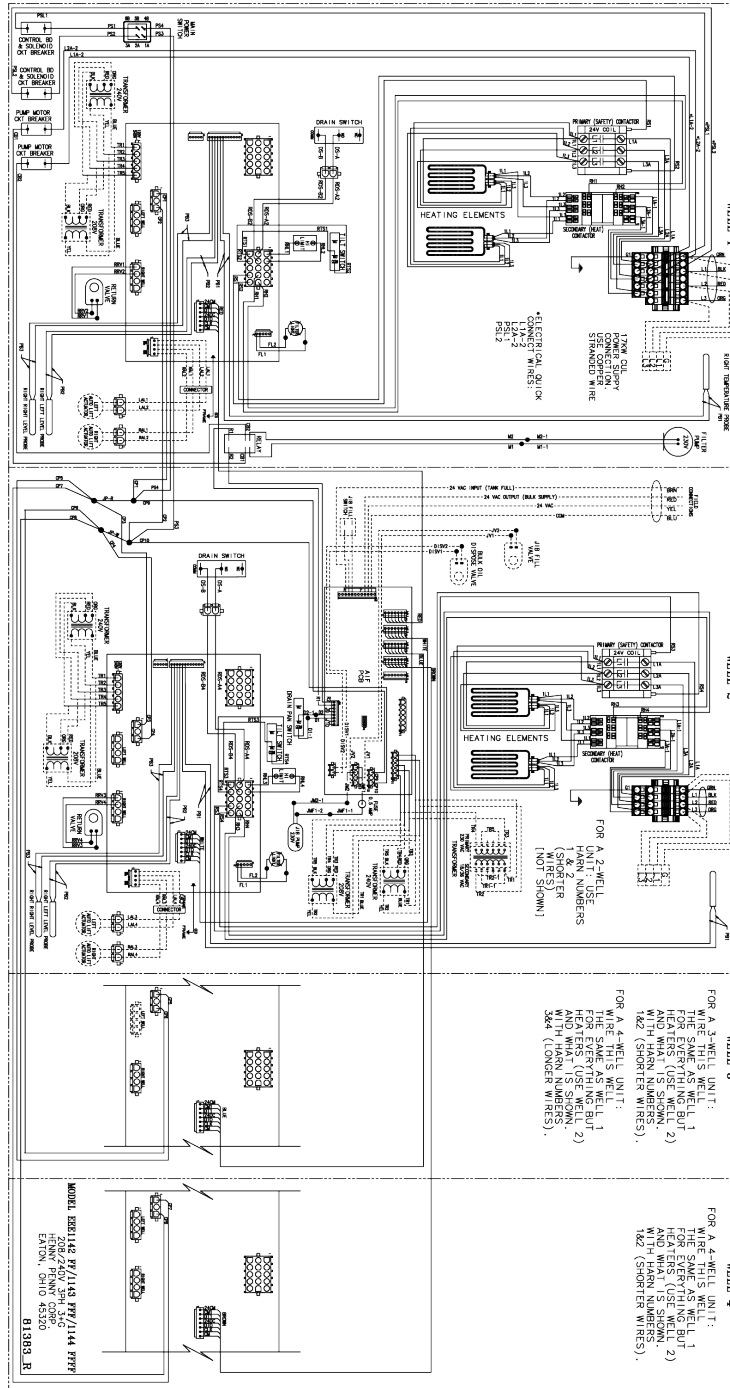

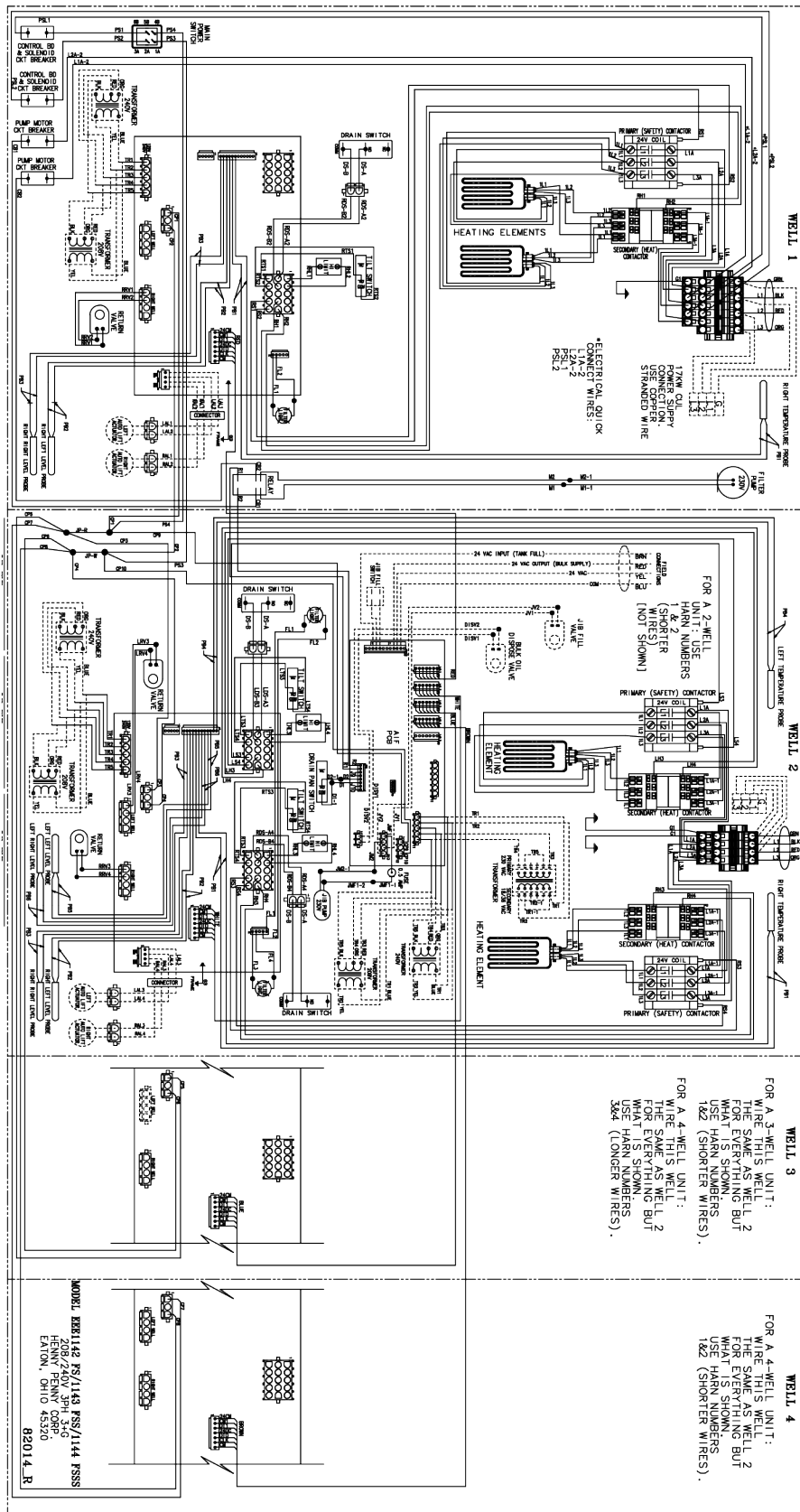

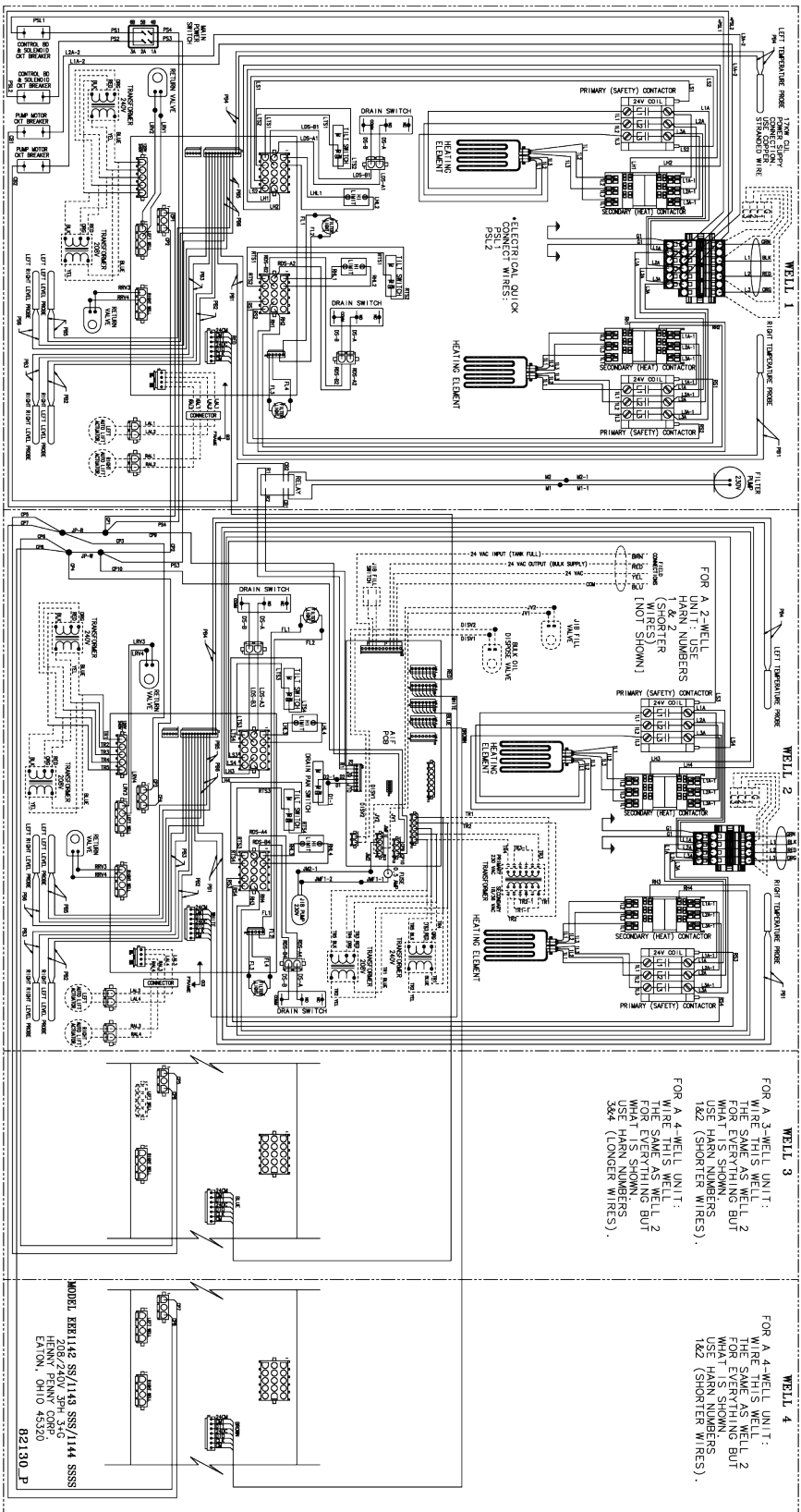

7.2 380-414 Volt

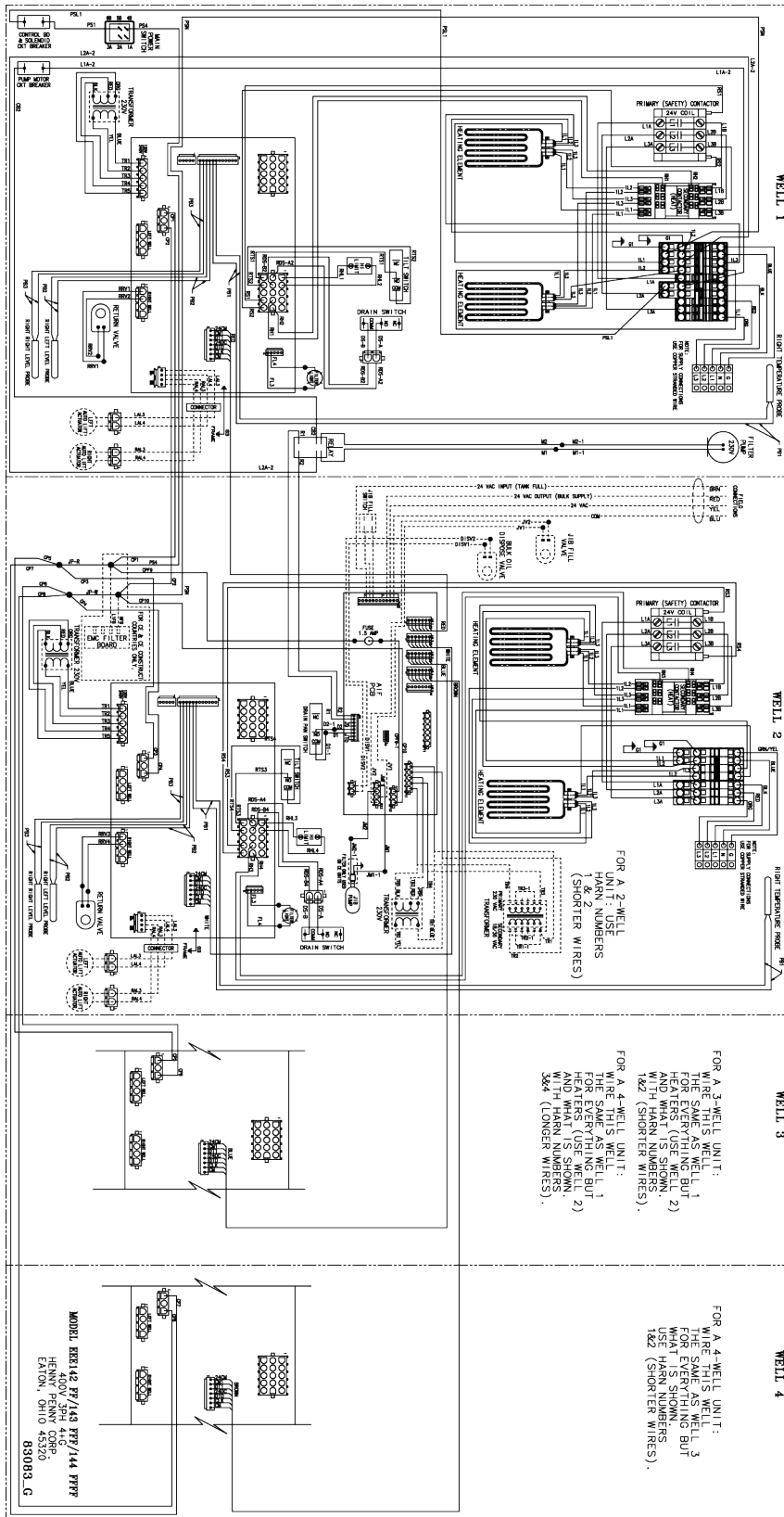

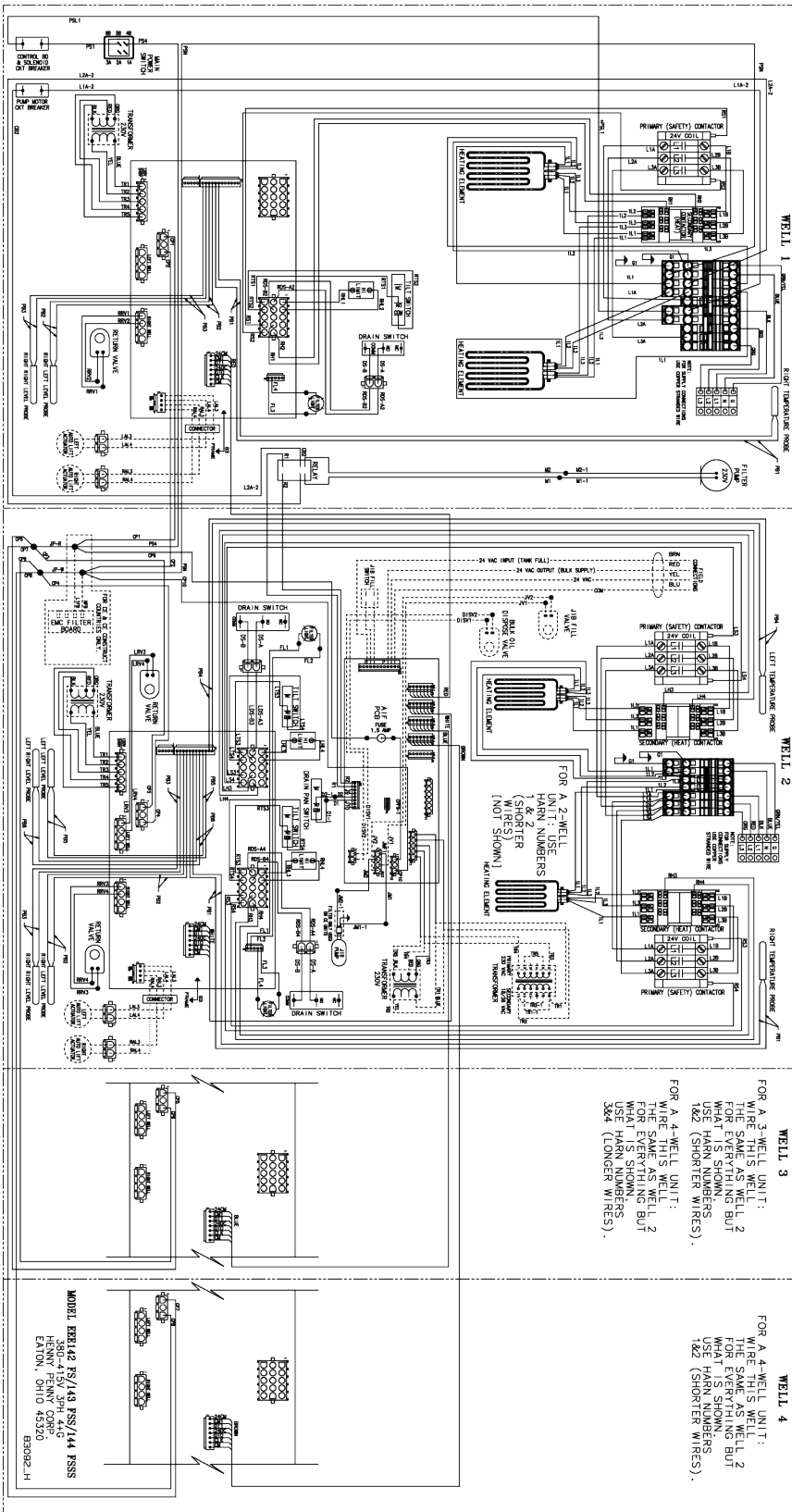

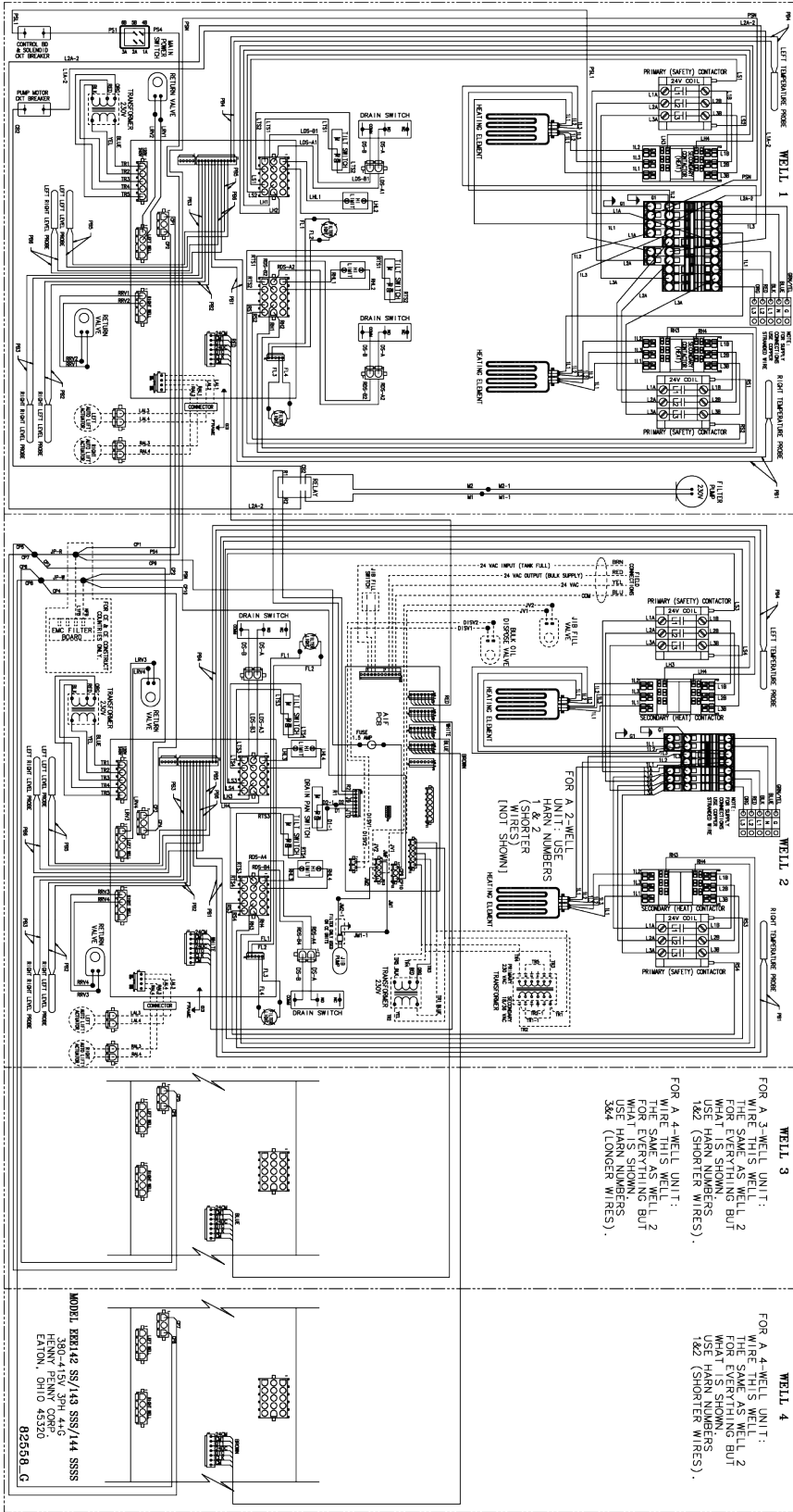

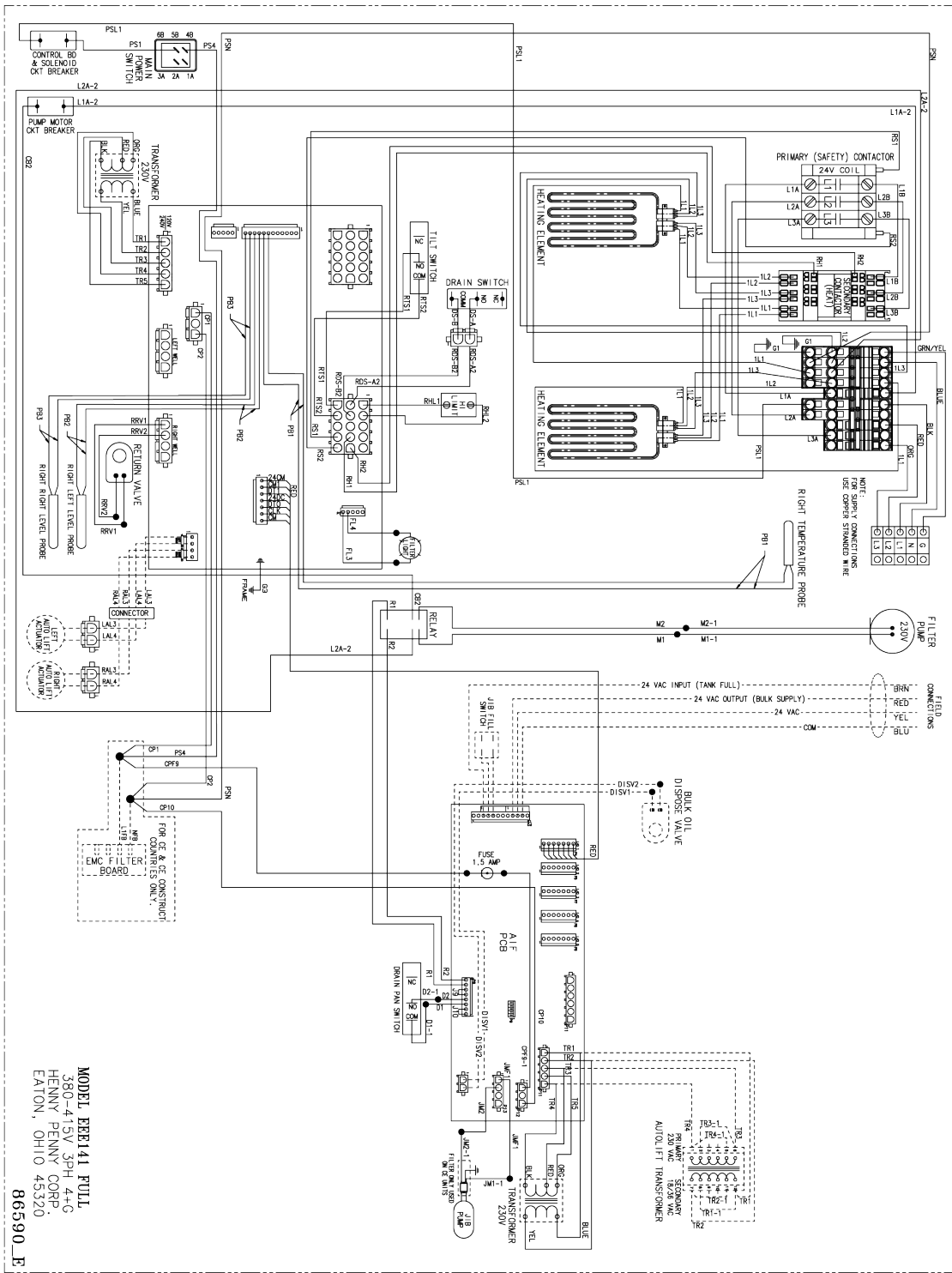

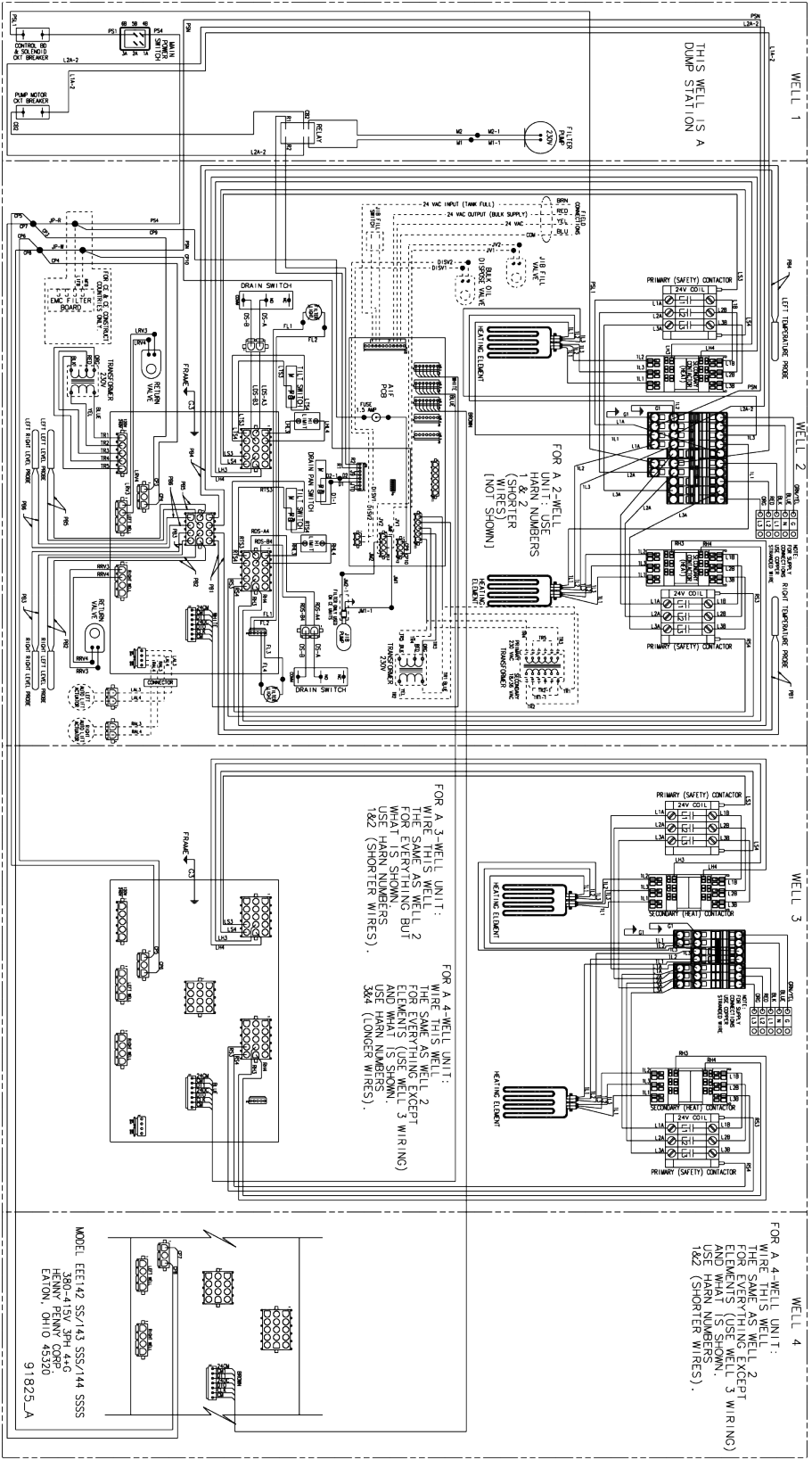

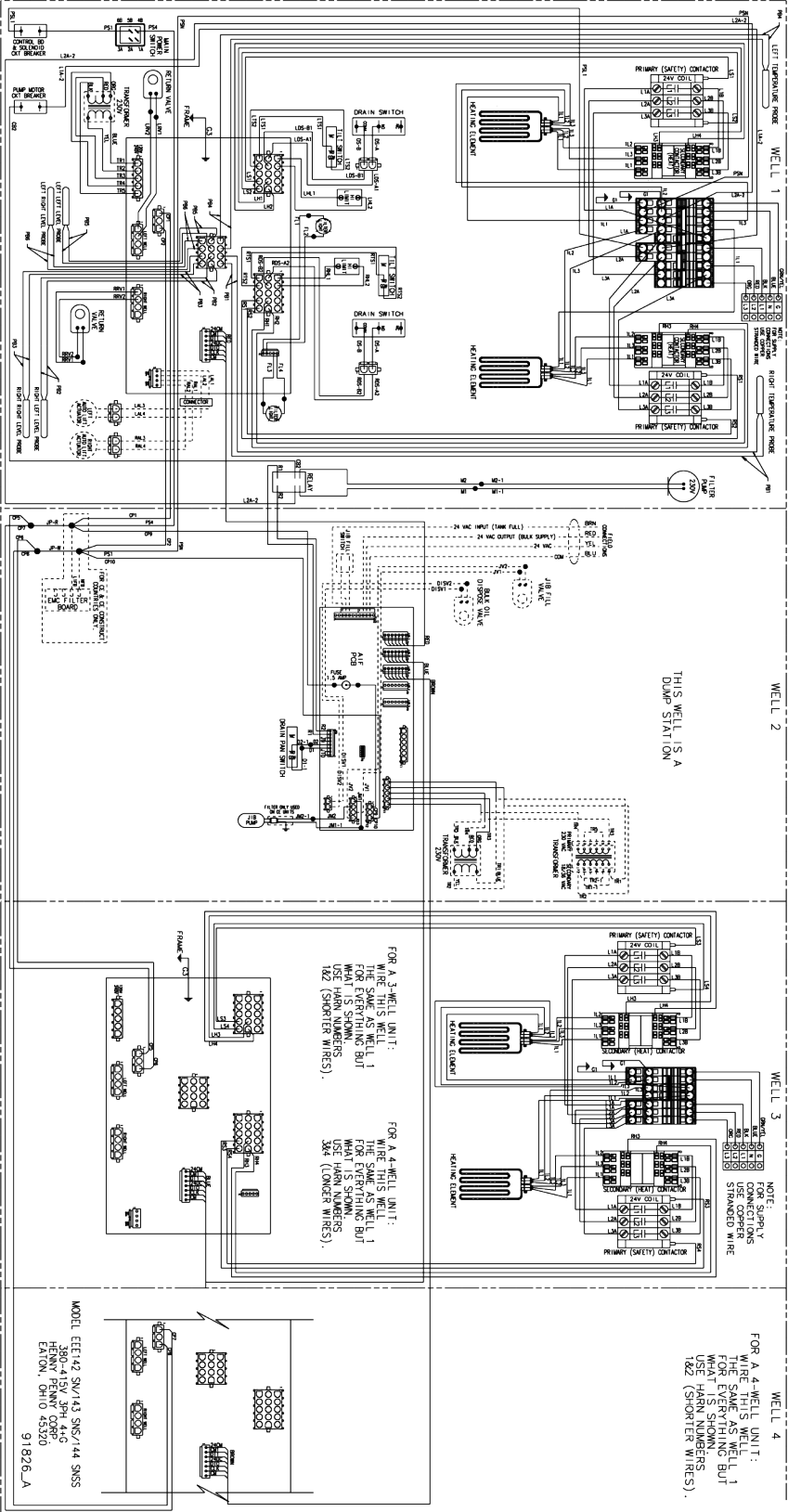



Henny Penny Corporation
P.O.Box 60
Eaton, OH 45320
www.hennypenny.com

Inside the U.S.:
1-800-417-8405
technicalservices@hennypenny.com

Outside the U.S.
1-937-456-8405
intltechsupport@hennypenny.com